

YAMAHA

PARTS CATALOGUE

WR200RD (4BF1)

WR200'92 (4BF1)

ALL

24BF-100E1

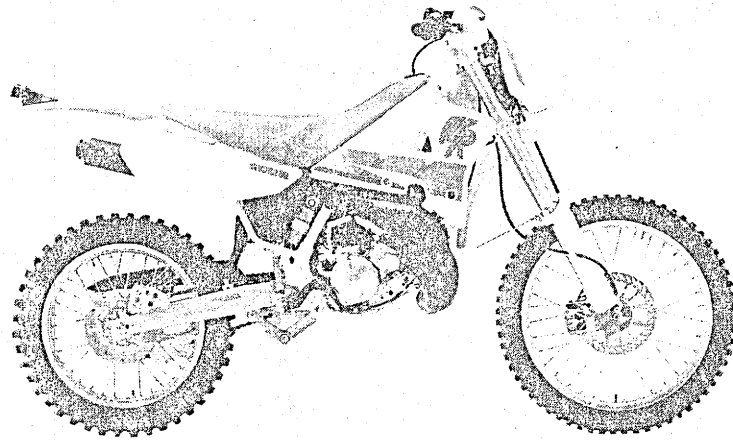

A3

FOREWORD

This Parts Catalogue is related to the parts in use for the Yamaha WR200RD/WR200'92(4BF1). When you are ordering replacement parts for the WR200RD/WR200'92(4BF1), refer to this Parts Catalogue and quote both part numbers and part names correctly.

1. Modifications or additions which have been made after issue of the Parts Catalogue will be announced in the Yamaha Parts News.

It is advisable that according to the Yamaha Parts News you make necessary corrections to the Parts Catalogue on hand to keep it up-to-date.

2. Abbreviations

The following abbreviations are used in this Parts Catalogue.

U.R. Use size (thickness) and/or number as required.

U.N. Use as many as you need.

A.P. Alternate Parts

L.M. Local Made

F# Frame No. (Applicable machine No.)

3. The parts marked with (*) in the parts number column of this Catalogue are not supplied with by Yamaha, those have to be found locally.

4. Parts, which are to be supplied in the form of assemblies, are listed with an indention of one letter's space, and a dot (.) is put against the name of each part.

EXAMPLE CARBURETOR ASS'Y
 . JET, pilot
 . NOZZLE, main

5. Indication of No. of constituent parts for assembly

The numeral appearing to the right of each constituent part under the description indicates the quantity of such parts for each individual assembly unit.

EXAMPLE

Part No.	Description	Q'ty	Remarks
2F5-83310-60	FRONT FLASHER LIGHT ASS'Y	2	
115-83311-60	. BULB (6V-18W)	1	
1M1-83309-60	. REFLECTOR	1	

6. Initial Serial No. and Color Code

(A) Frame Serial No.	4BF-000101 and following
(B) Engine Serial No.	4BF-000101 and following

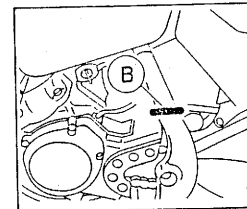
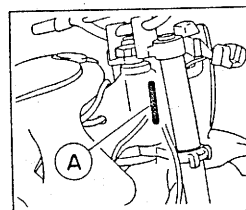

Color Code	Color Name	Abbreviate
0206	PURPLISH WHITE SOLID 1	PWS1

7. Applicable colors of graphics are represented in the "Remarks" column by the letter(s) appropriately picked out of the full word(s) showing such colors.

EXAMPLE

Part No.	Description	Q'ty	Remarks
2N4-24110-00-X5	FUEL TANK COMP.	1	MAXIM RED
3J1-24240-10	. GRAPHIC, fuel tank set	1	for MXR

CONTENTS

ENGINE

Cylinder	B2 ~ B3
Crankshaft, Piston	B4 ~ B5
Water Pump	B6
Radiator, Hose	B7 ~ B8
Intake	B9 ~ B10
Carburetor	B11 ~ B12
Exhaust	B13
Crankcase	B14
Crankcase Cover 1	B15
Starter	C2
Clutch	C3 ~ C4
Transmission	C5 ~ C6
Shift Cam. Fork	C7
Shifter	C8

CHASSIS

Frame	C9
Fender	C10
Side Cover	C11 ~ C12
Oil Tank	C13
Rear Arm	C14 ~ C15
Rear Suspension	D2
Steering	D3
Front Fork	D4 ~ D5
Fuel Tank	D6
Seat	D7
Front Wheel	D8
Front Brake Caliper	D9
Rear Wheel	D10

Rear Brake Caliper	D11
Steering Handle, Cable	D12
Front Master Cylinder	D13
Stand, Footrest	D14
Rear Master Cylinder	D15
Generator	E2
Meter	E3
Headlight	E4
Taillight	E5
Handle Switch, Lever	E6
Electrical 1	E7

INDEX

Numerical Index	M1 ~ M3
-----------------------	---------

FIG. 1 CYLINDER

REF. NO.	PART NO.	DESCRIPTION	Q'TY	REMARKS
1	3XP-11111-00	HEAD, cylinder 1	1	
2	90116-08394	BOLT, stud	5	
3	90176-08040	NUT, crown	5	
4	90201-08649	WASHER, plate	5	
5	94701-00188	PLUG, spark (NGK BR9ES)	1	
6	3XP-11181-00	GASKET, cylinder head 1	1	
7	3XP-11311-00	CYLINDER 1	1	
8	3XP-11351-00	GASKET, cylinder	1	
9	90116-08318	BOLT, stud	2	
10	90116-08388	BOLT, stud	2	
11	99510-10114	PIN, dowel	2	
12	90179-08491	NUT	4	
13	3XP-1131A-00	VALVE 1	1	
14	3RR-1131E-00	HOLDER 1	1	
15	90462-08201	CLAMP	1	
16	3RR-1131N-00	GASKET, holder	1	
17	91316-05012	BOLT	2	
18	31K-1131U-00	HOLDER 3	1	
19	93108-23010	OIL SEAL	1	
20	93210-30640	O-RING	1	
21	2RH-1131M-10	COVER	1	
22	91311-05010	BOLT	2	
23	2RH-1131R-10	CAP, seal	1	
24	91311-05012	BOLT	2	
25	29L-1132E-00	PULLEY 1	1	
26	97026-06018	BOLT	1	
27	92906-06100	WASHER, spring	1	
28	92906-06600	WASHER, plate	1	

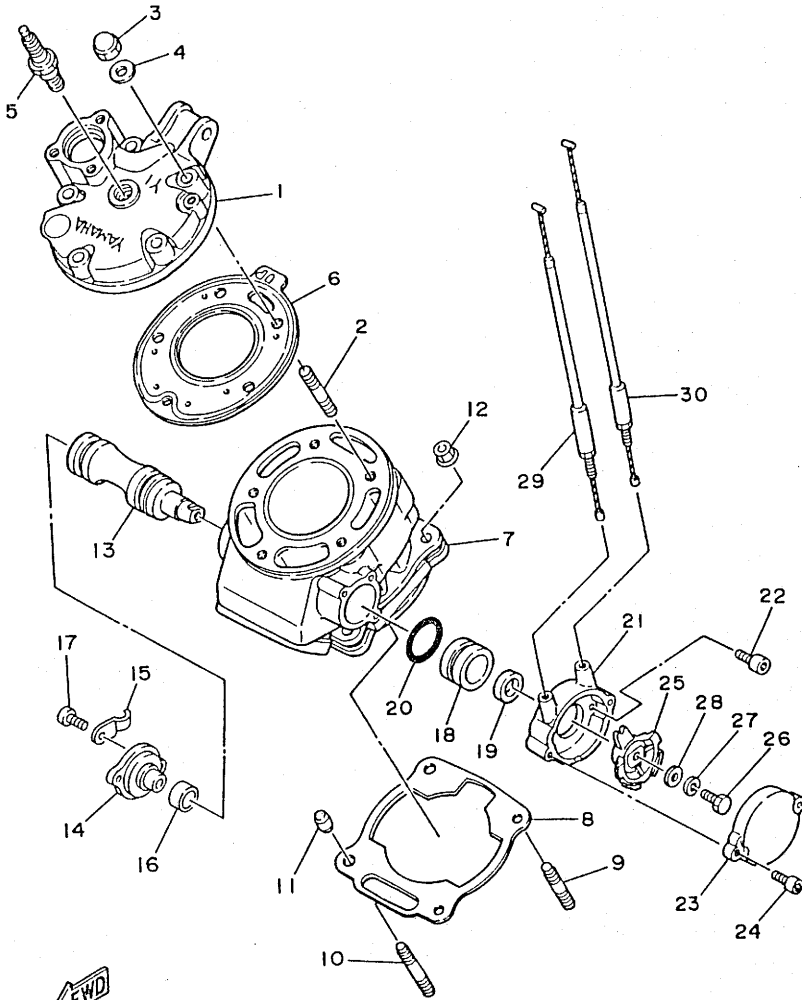

3XP1010-1010

FIG. 1 CYLINDER

REF. NO.	PART NO.	DESCRIPTION	Q'TY	REMARKS
29	3XP-1133E-00	CABLE, pulley 1	1	
30	3BN-1133F-00	CABLE, pulley 2	1	

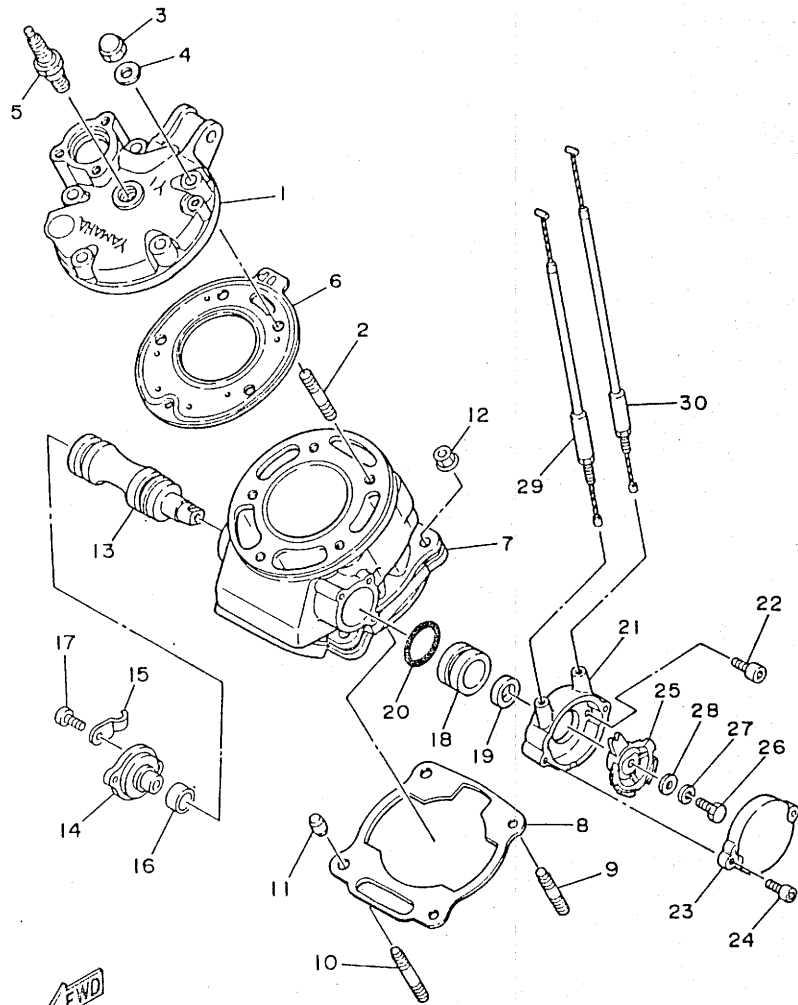

3XP1010-1010

B3

FIG. 2 CRANKSHAFT. PISTON

REF. NO.	PART NO.	DESCRIPTION	Q'TY	REMARKS
1	3XP-11400-00	CRANKSHAFT ASSY	1	
2	3XP-11412-00	.CRANK 1	1	
3	3XP-11422-00	.CRANK 2	1	
4	2TV-11651-00	.ROD, connecting	1	
5	37F-11681-00	.PIN, crank 1	1	
6	90209-22257	.WASHER	2	
7	93310-52302	.BEARING, cylindrical	1	
8	3XP-11631-00-A0	PISTON (STD)	1	UR RED
	3XP-11631-00-B0	PISTON (STD)	1	UR ORANGE
	3XP-11631-00-C0	PISTON (STD)	1	UR GREEN
	3XP-11631-00-D0	PISTON (STD)	1	UR PURPLE
9	3XP-11610-00	PISTON RING SET (STD)	1	
10	93310-316C9	BEARING, cylindrical	1	
11	4H7-11633-00	PIN, piston	1	
12	93450-17129	CIRCLIP	2	
13	93306-30556	BEARING	2	
14	93102-25331	OIL SEAL	1	
15	93103-32171	OIL SEAL	1	
16	90387-202T9	COLLAR	1	
17	90280-03045	KEY, woodruff	1	
18	90282-05047	KEY, straight	1	
19	10V-11536-01	GEAR, drive	1	
20	2TV-11454-00	WEIGHT 1	1	
21	93306-30210	BEARING	1	
22	93306-20335	BEARING	1	
23	90282-05058	KEY, straight	1	
24	55K-11530-00	BALANCER WIEGHT GEAR COMP.43T	1	
25	90215-12272	WASHER, lock	1	

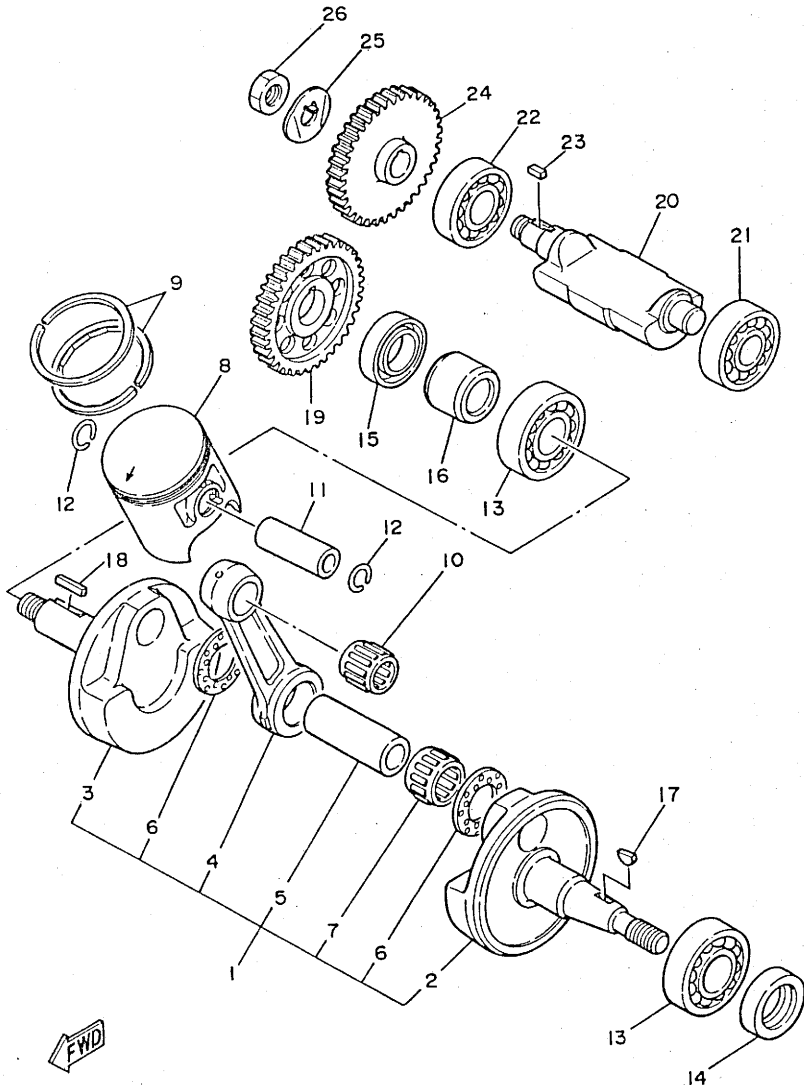

FWD

2TV010-7020

B4

FIG. 2 CRANKSHAFT. PISTON

REF. NO.	PART NO.	DESCRIPTION	Q'TY	REMARKS
26	90170-12370	NUT	1	

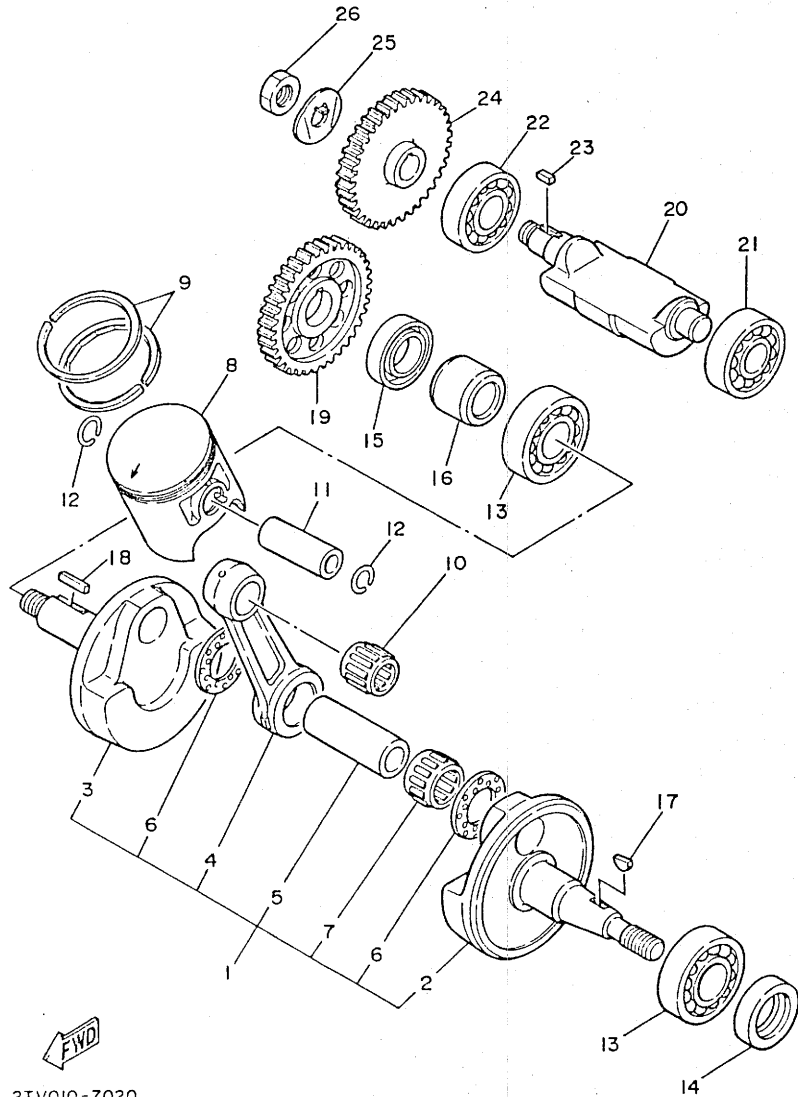

2TV010-7020

B5

FIG. 3 WATER PUMP

REF. NO.	PART NO.	DESCRIPTION	Q'TY	REMARKS
1	36F-12450-00	IMPELLER SHAFT ASSY	1	
2	93103-10147	OIL SEAL	1	
3	93603-22028	PIN, dowel	1	
4	2TV-12459-00	GEAR, impeller shaft	1	
5	90201-08512	WASHER, plate	2	
6	99080-07600	CIRCLIP	1	
7	3BN-12422-11	COVER, housing	1	
8	3BN-12428-10	GASKET, housing cover 2	1	
9	93604-10011	PIN, dowel	2	
10	98501-06025	SCREW, pan head	1	
11	98501-06065	SCREW, pan head	1	
12	95811-06025	BOLT, flange	1	
13	90430-06166	GASKET	1	

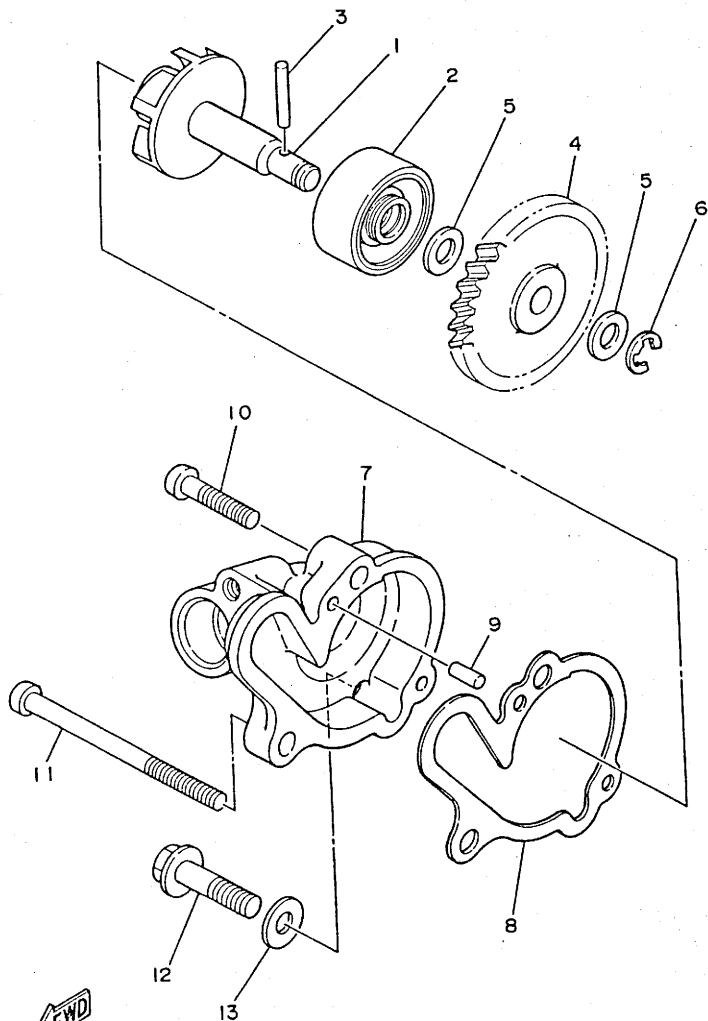

FWD

3BN300-8030

B6

FIG. 4 RADIATOR. HOSE

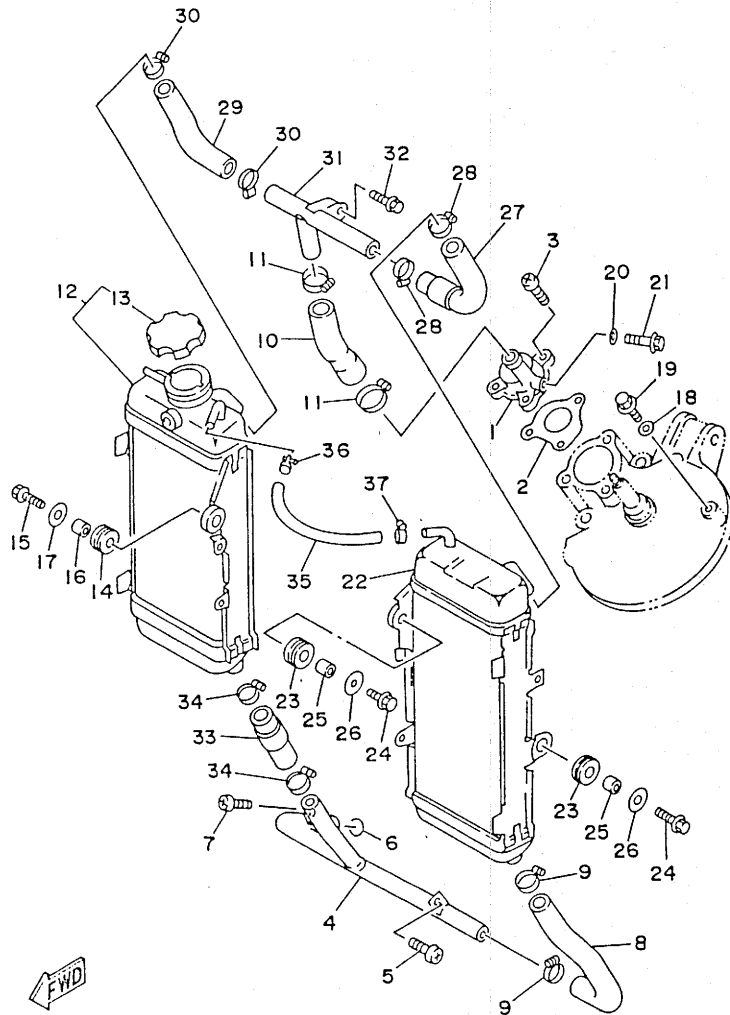

4BF1100-2040

REF. NO.	PART NO.	DESCRIPTION	Q'TY	REMARKS
1	3BN-12469-00	JOINT 1	1	
2	3BN-12414-10	GASKET, cover	1	
3	98516-06020	SCREW, pan head	3	
4	3XP-12481-00	PIPE 1	1	
5	98501-06012	SCREW, pan head	1	
6	93210-12327	O-RING	1	
7	98501-06012	SCREW, pan head	1	
8	3XP-12482-00	PIPE 2	1	
9	90450-22052	HOSE CLAMP ASSY	2	
10	3XP-12483-00	PIPE 3	1	
11	90450-28014	HOSE CLAMP ASSY	2	
12	3XP-12460-00	RADIATOR ASSY	1	
13	3XP-12462-00	.CAP, radiator	1	
14	90480-18276	GROMMET	2	
15	95023-06025	BOLT	2	
16	90387-07573	COLLAR	2	
17	90201-06570	WASHER, plate	2	
18	90430-06166	GASKET	1	
19	95826-06010	BOLT, flange	1	
20	90430-06166	GASKET	1	
21	95826-06010	BOLT, flange	1	
22	4BF-1240A-00	RADIATOR ASSY 2	1	
23	90480-15064	GROMMET	2	
24	95023-06025	BOLT	2	
25	90387-07392	COLLAR	2	
26	90201-06570	WASHER, plate	2	
27	3XP-12484-00	PIPE 4	1	
28	90450-22052	HOSE CLAMP ASSY	2	

B7

FIG. 4 RADIATOR. HOSE

REF. NO.	PART NO.	DESCRIPTION	Q'TY	REMARKS
29	3XP-12485-00	PIPE 5	1	
30	90450-22052	HOSE CLAMP ASSY	2	
31	3XP-12469-00	JOINT 1	1	
32	95801-06010	BOLT, flange	1	
33	3XP-12476-00	PIPE 6	1	
34	90450-22052	HOSE CLAMP ASSY	2	
35	1LU-1248A-01	PIPE 8	1	
36	90450-15041	HOSE CLAMP ASSY	1	
37	90450-17036	HOSE CLAMP ASSY	1	

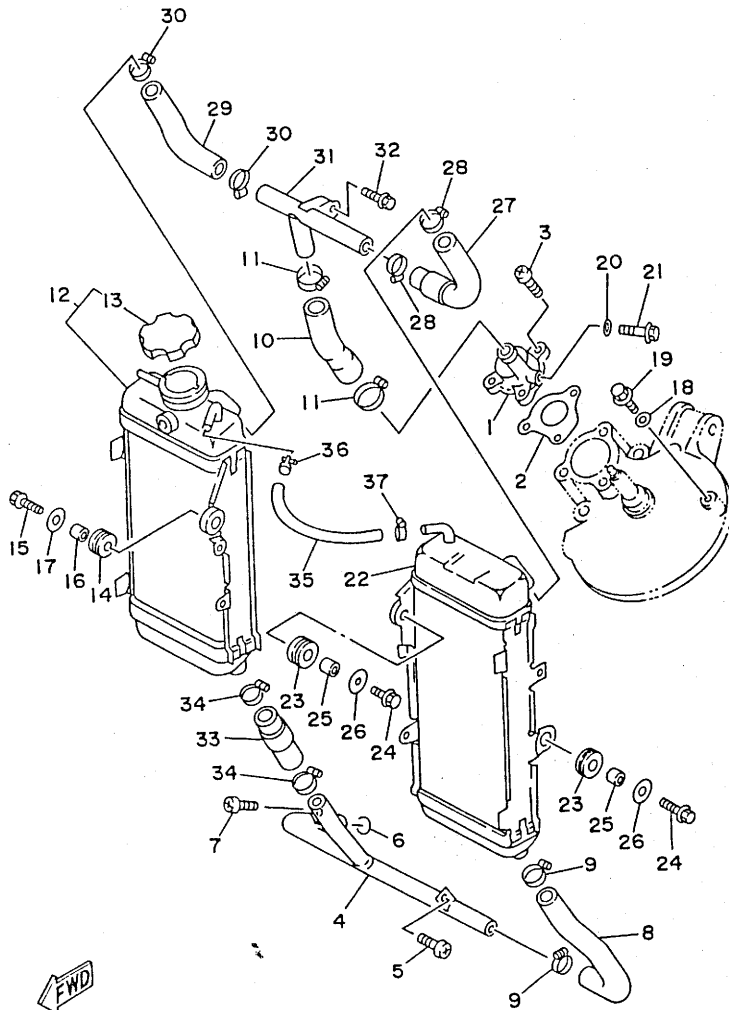

4BF1100-2040

B3

FIG. 5 INTAKE

REF. NO.	PART NO.	DESCRIPTION	Q'TY	REMARKS
1	1LX-13610-01	REED VALVE ASSY	1	
2	55Y-13613-00	.REED, valve	2	
3	55Y-13616-00	.STOPPER, reed valve	2	
4	98580-03008	.SCREW, pan head	6	
5	92990-03100	.WASHER, spring	6	
6	3XP-13621-00	GASKET, valve seat	1	
7	3XP-13565-00	JOINT, carburetor	1	
8	90450-49020	HOSE CLAMP ASSY	1	
9	95026-06020	BOLT, flange	4	
10	3XP-14411-00	CASE, air cleaner 1	1	
11	3XP-14421-00	CASE, air cleaner 2	1	
12	97706-50520	SCREW, tapping	7	
13	3XP-14453-00	JOINT, air cleaner 1	1	
14	90450-99013	HOSE CLAMP ASSY	1	
15	4BF-14451-00	ELEMENT, air cleaner	1	
16	3XP-14458-00	GUIDE	1	
17	3XP-14459-00	HOLDER, guide	1	
18	90209-06096	WASHER	1	
19	90122-06013	BOLT, wing	1	
20	3XP-14412-00	CAP, cleaner case 1	1	
21	3XP-14437-00	DUCT	1	
22	3AJ-1443E-00	PIPE, drain	1	
23	90467-15012	CLIP	1	
24	90480-08216	GROMMET	1	
25	90149-06200	SCREW	2	
26	43G-14436-00	HOOK	2	
27	90267-40075	RIVET, blind	4	
28	92901-04600	WASHER, plate	4	

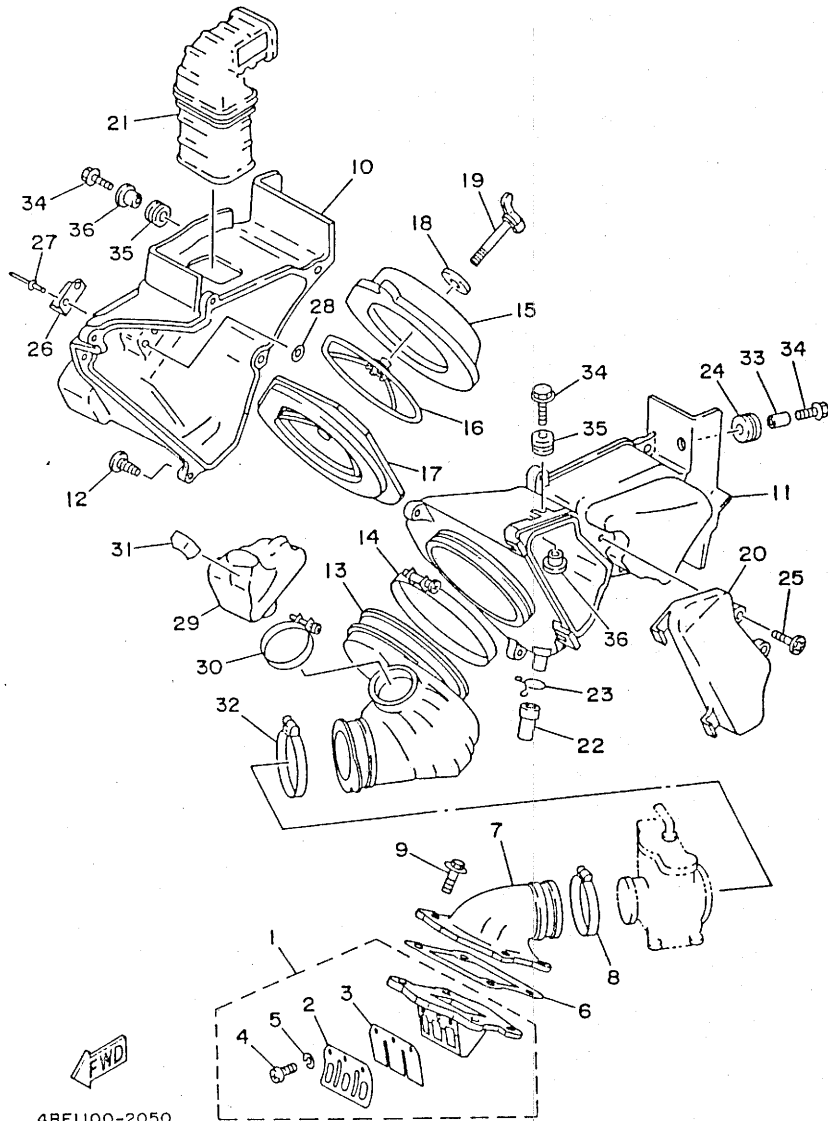

4BF1100-2050

B9

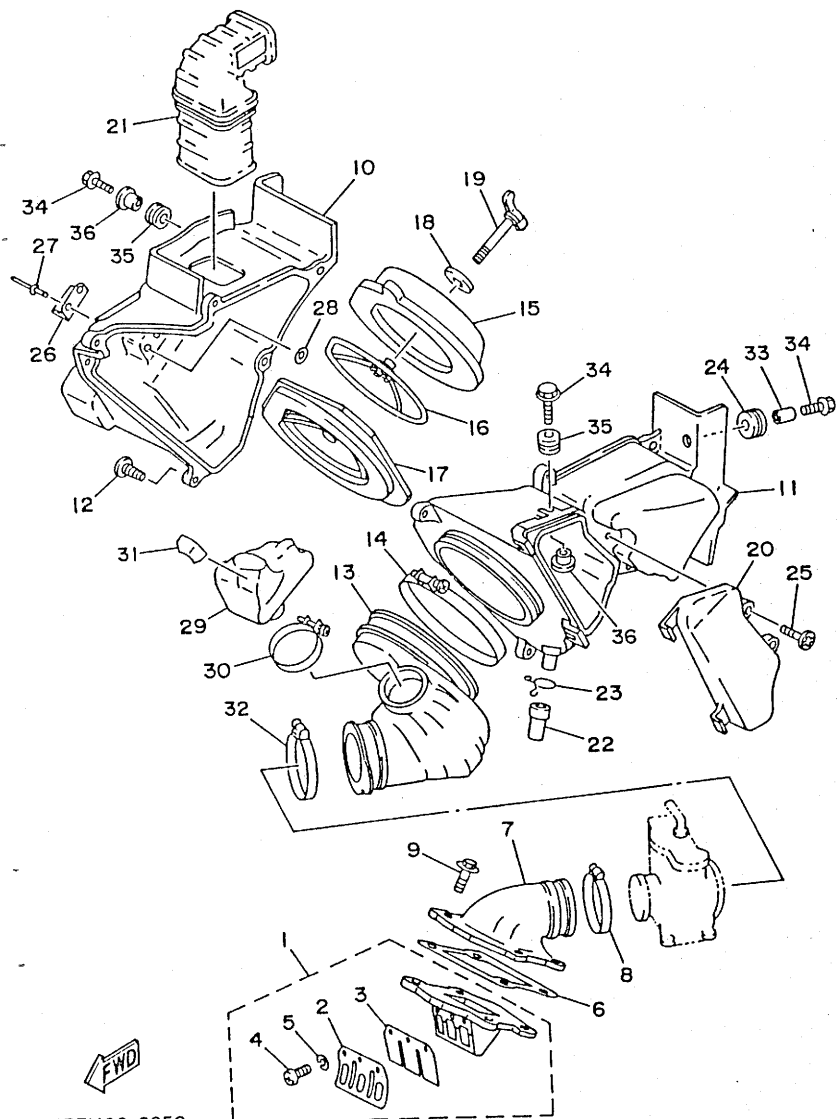
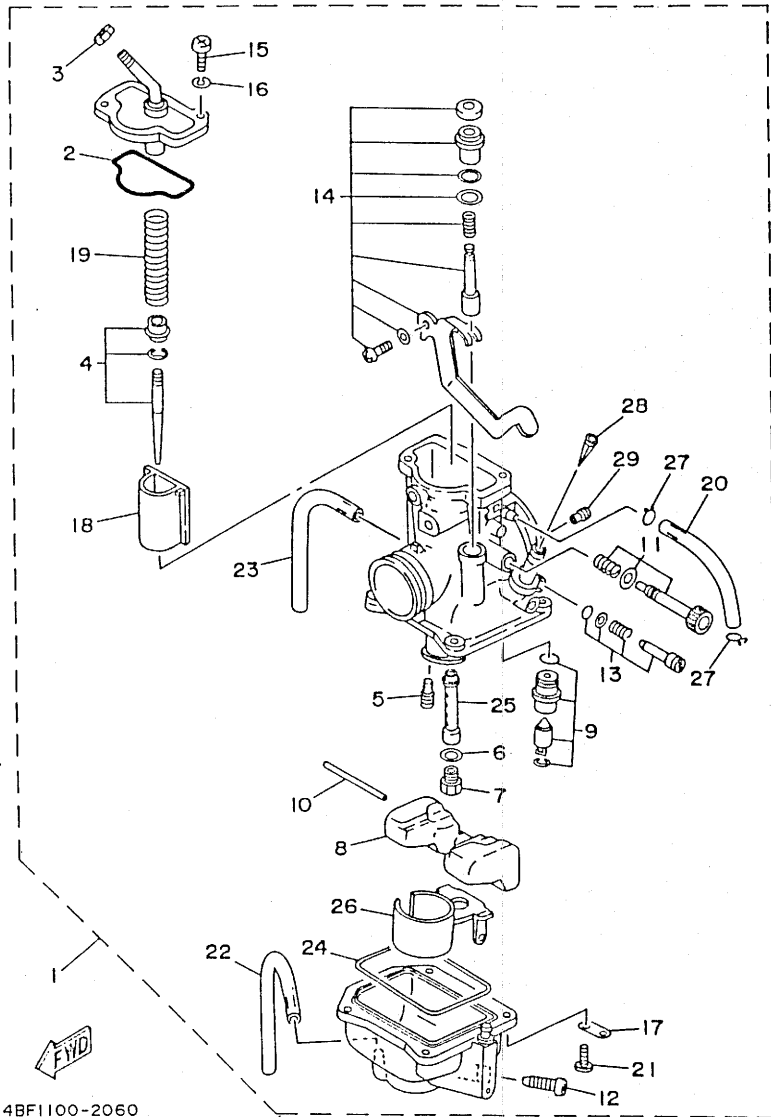

FIG. 5 INTAKE

REF. NO.	PART NO.	DESCRIPTION	Q'TY	REMARKS
29	3XP-13591-00	CHAMBER, air 2	1	
30	90460-32182	CLAMP, hose	1	
31	1AE-2834F-00	DAMPER	1	
32	90460-61063	CLAMP, hose	1	
33	90387-06241	COLLAR	1	
34	90119-06118	BOLT, with washer	3	
35	90480-12067	GROMMET	2	
36	90387-06737	COLLAR	2	



4BF1100-2050



4BF1100-2060

FIG. 6 CARBURETOR

REF. NO.	PART NO.	DESCRIPTION	Q'TY	REMARKS
1	4BF-14101-00	CARBURETOR ASSY 1	1	
2	3JD-14147-00	.O-RING	1	
3	127-14161-00	.NUT, cable adjusting	1	
4	3XP-1490J-10	.NEEDLE SET	1	
5	193-14142-35	.JET,pilot (=35)	1	
6	137-14153-00	.WASHER, main jet	1	
7	137-14143-42-A1	.JET, main (=210)	1	
8	3XP-14185-00	.FLOAT	1	
9	3XP-14190-30	.NEEDLE VALVE ASSY	1	
10	353-14186-00	.PIN, float	1	
11	3XP-14103-00	.THROTTLE SCREW SET	1	
12	12R-14191-00	.PLUG, drain	1	
13	3XP-14104-00	.AIR SCREW SET	1	
14	3XP-1410A-00	.STARTER SET	1	
15	98511-04012	.SCREW, pan head	2	
16	92902-04100	.WASHER, spring	2	
17	313-14146-00	.PLATE	2	
18	3XP-14112-40	.VALVE, throttle l	1	
19	3XP-14931-00	.SPRING, throttle lever	1	
20	3XP-14987-00	.HOSE	1	
21	98506-05014	.SCREW, pan head	4	
22	3KD-14197-00	.PIPE	1	
23	310-14197-00	.PIPE	2	
24	3XP-14229-00	.SEAL	1	
25	3XP-14141-28	.NOZZLE, main	1	
26	3XP-14261-00	.HOLDER	1	
27	8A7-14139-00	.CLIP, pipe	2	
28	1KT-14994-00	.NET, filter	1	

B11

FIG. 6 CARBURETOR

REF. NO.	PART NO.	DESCRIPTION	Q'TY	REMARKS
29	239-14172-08	.PILOT JET, air (0.8)	1	

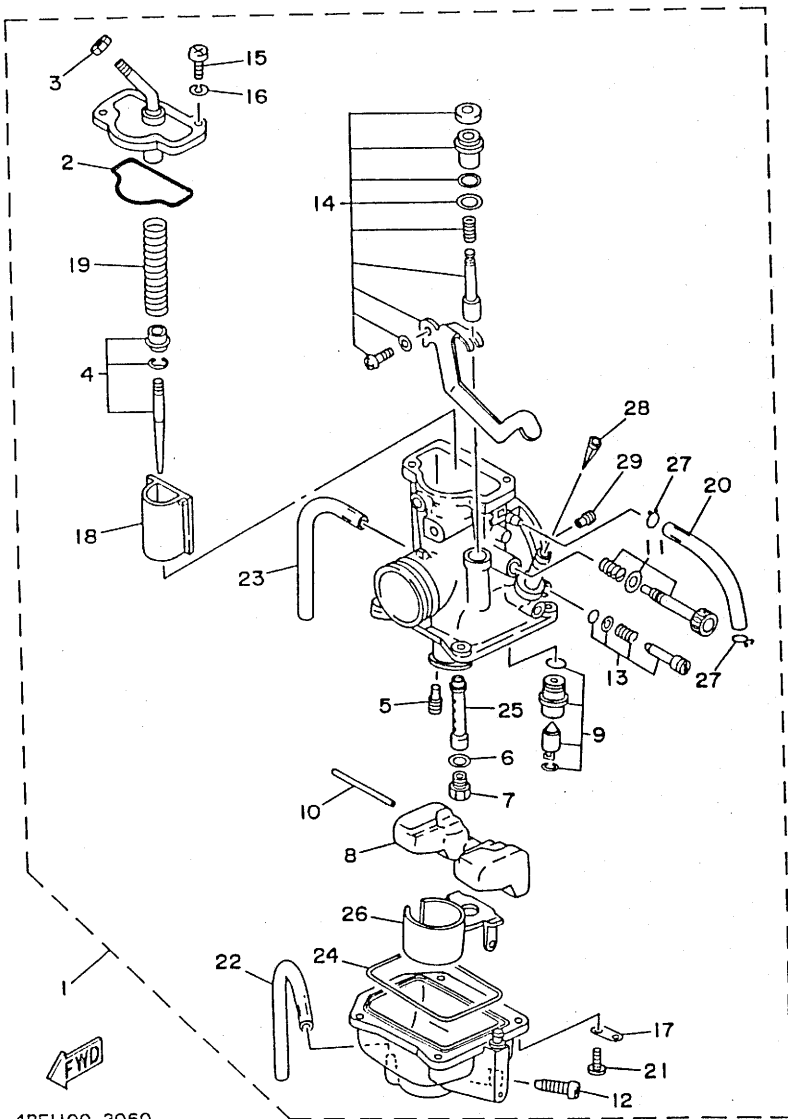

4BF1100-2060

B12

FIG. 7 EXHAUST

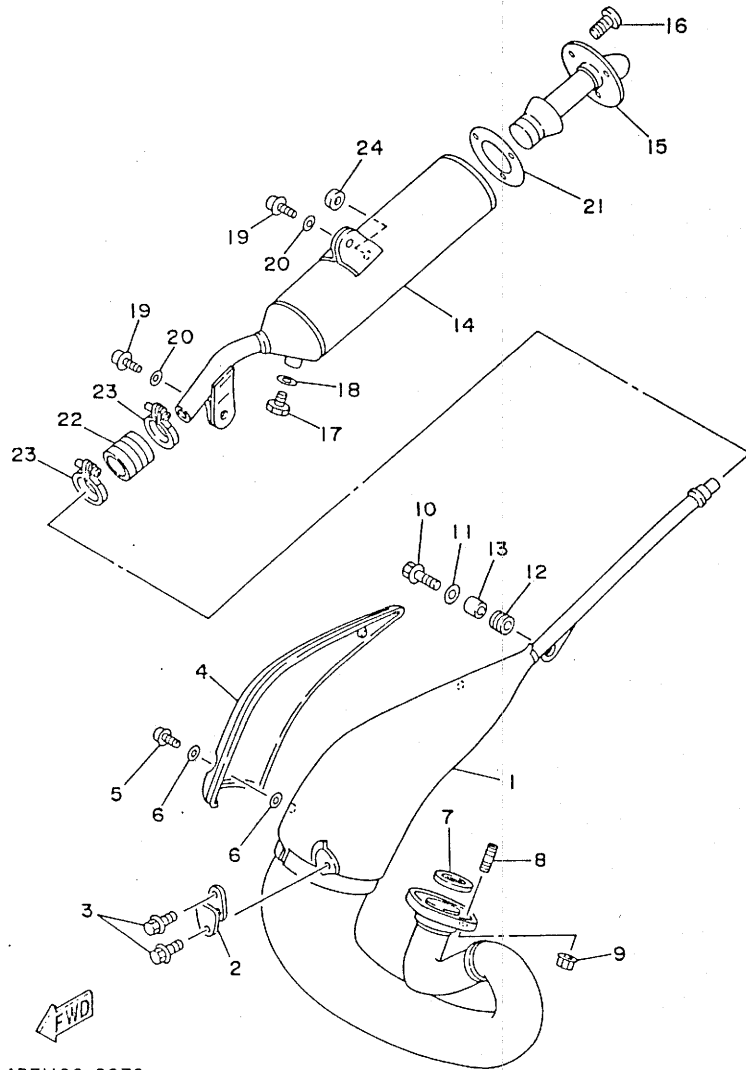

REF. NO.	PART NO.	DESCRIPTION	Q'TY	REMARKS
1	3XP-14610-00	EXHAUST PIPE ASSY 1	1	
2	565-14771-00	STAY, muffler 1	1	
3	95816-06012	BOLT, flange	2	
4	3XP-14718-00	PROTECTOR, muffler 1	1	
5	98906-06010	SCREW, bind	2	
6	90202-05187	WASHER, plate	4	
7	3PA-14613-10	GASKET, exhaust pipe	1	
8	90116-08042	BOLT, stud	2	
9	90179-08270	NUT	2	
10	95816-06025	BOLT, flange	1	
11	90201-060A3	WASHER, plate	1	
12	90480-18411	GROMMET	1	
13	90387-105L0	COLLAR	1	
14	4BF-14753-00	SILENCER, exhaust	1	
15	2GU-14752-00	PIPE, outlet	1	
16	98906-06010	SCREW, bind	3	
17	90101-06576	BOLT	1	
18	92906-06600	WASHER, plate	1	
19	90109-085E2	BOLT	2	
20	90201-081H4	WASHER, plate	2	
21	2GU-14613-00	GASKET, exhaust pipe	1	
22	3XP-14714-00	GASKET, muffler	1	
23	90460-37026	CLAMP, hose	2	
24	157-27114-00	STOPPER, main stand	1	

4BF1100-2070

B13

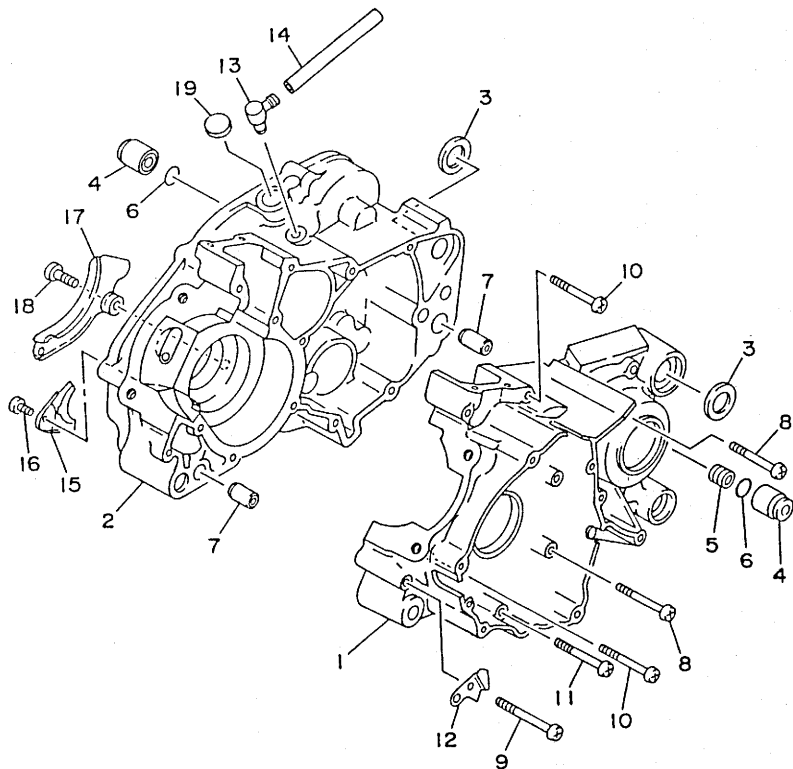

FIG. 8 CRANKCASE

REF. NO.	PART NO.	DESCRIPTION	Q'TY	REMARKS
1	3XP-15111-00	CRANKCASE 1	1	
2	3XP-15121-00	CRANKCASE 2	1	
3	90201-170M2	WASHER, plate	2	
4	328-15316-00	DAMPER, engine mount 1	2	
5	3XP-15317-00	SPACER, engine mount	1	
6	93210-12154	O-RING	2	
7	99510-12016	PIN, dowel	2	
8	98501-06060	SCREW, pan head	4	
9	98501-06065	SCREW, pan head	1	
10	98501-06050	SCREW, pan head	6	
11	98501-06070	SCREW, pan head	2	
12	3BN-15199-00	BRACKET	1	
13	3YJ-15371-00	BREATHER	1	
14	90446-07349	HOSE	1	
15	37F-15128-00	HOLDER	1	
16	98511-08010	SCREW, pan head	1	
17	2RH-15492-00	COVER	1	
18	98502-06012	SCREW, pan head	2	
19	90338-16029	PLUG	1	



3XP1010-1090

B14

FIG. 9 CRANKCASE COVER 1

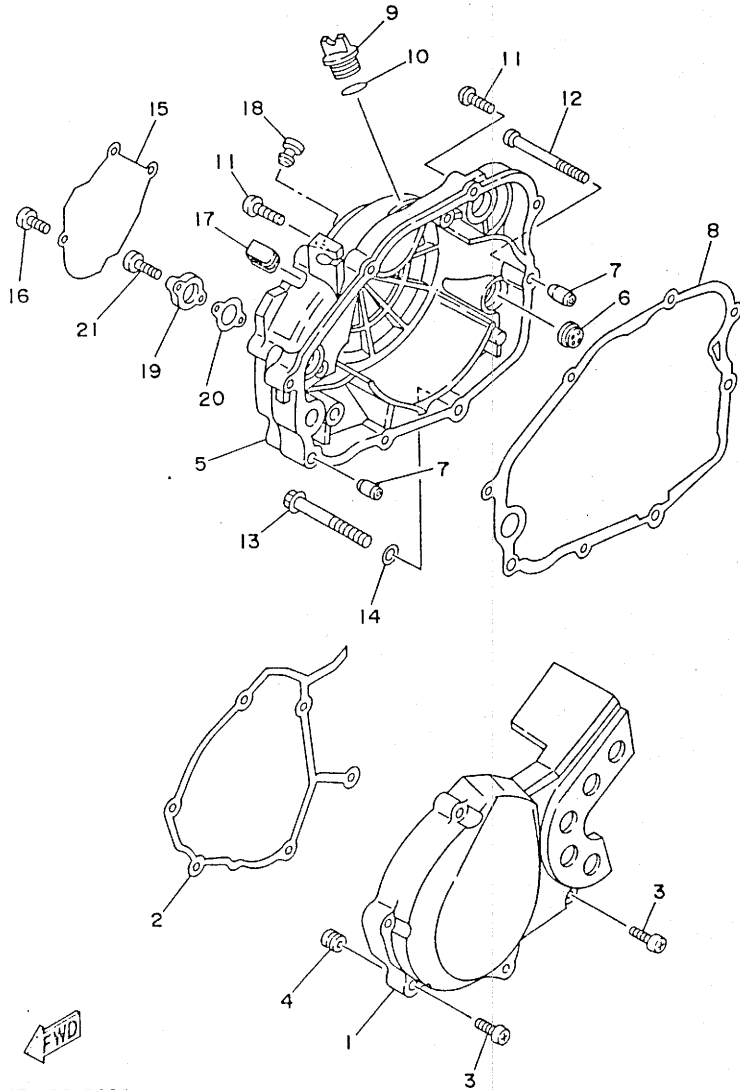

REF. NO.	PART NO.	DESCRIPTION	Q'TY	REMARKS
1	3BN-15411-10	COVER, crankcase 1	1	
2	3ET-15379-00	SEAL, crankcase	1	
3	90157-06115	SCREW, pan head	6	
4	90480-09481	GROMMET	6	
5	3XP-15421-00	COVER, crankcase 2	1	
6	3Y1-15361-00	GAUGE, level	1	
7	99530-10014	PIN, dowel	2	
8	3BN-15451-10	GASKET, crankcase cover 1	1	
9	1RG-15363-00	PLUG, oil	1	
10	93210-19123	O-RING	1	
11	98501-06030	SCREW, pan head	5	
12	98501-06040	SCREW, pan head	1	
13	95801-08080	BOLT, flange	1	
14	90201-08087	WASHER, plate	1	
15	4BF-15416-00	COVER, oil pump	1	
16	98501-06012	SCREW, pan head	3	
17	4BF-15357-00	GROMMET	1	
18	4BF-15189-00	PLUG	1	
19	161-15426-00	COVER, pump unit	1	
20	3MT-13116-00	GASKET, pump case	1	
21	98501-05016	SCREW, pan head	2	

4BF1100-2090

B15

FIG. 10 STARTER

REF. NO.	PART NO.	DESCRIPTION	Q'TY	REMARKS
1	10V-15660-00	KICK AXLE ASSY	1	
2	10V-15641-00	GEAR, kick (23T)	1	
3	90468-26048	CLIP	1	
4	90201-200J7	WASHER, plate	1	
5	90508-26667	SPRING, torsion	1	
6	10V-15666-00	SPACER	1	
7	10V-15651-00	GEAR, kick idle (29T)	1	
8	90201-154E8	WASHER, plate	2	
9	93440-15012	CIRCLIP	2	
10	3XP-15620-00	KICK CRANK ASSY	1	
11	3XP-15621-00	.BOSS, kick crank	1	
12	90501-12081	.SPRING, compression	1	
13	93507-32031	.BALL	1	
14	90201-12631	.WASHER, plate	1	
15	93430-08007	.CIRCLIP	1	
16	90179-12244	NUT	1	
17	93102-20309	OIL SEAL	1	

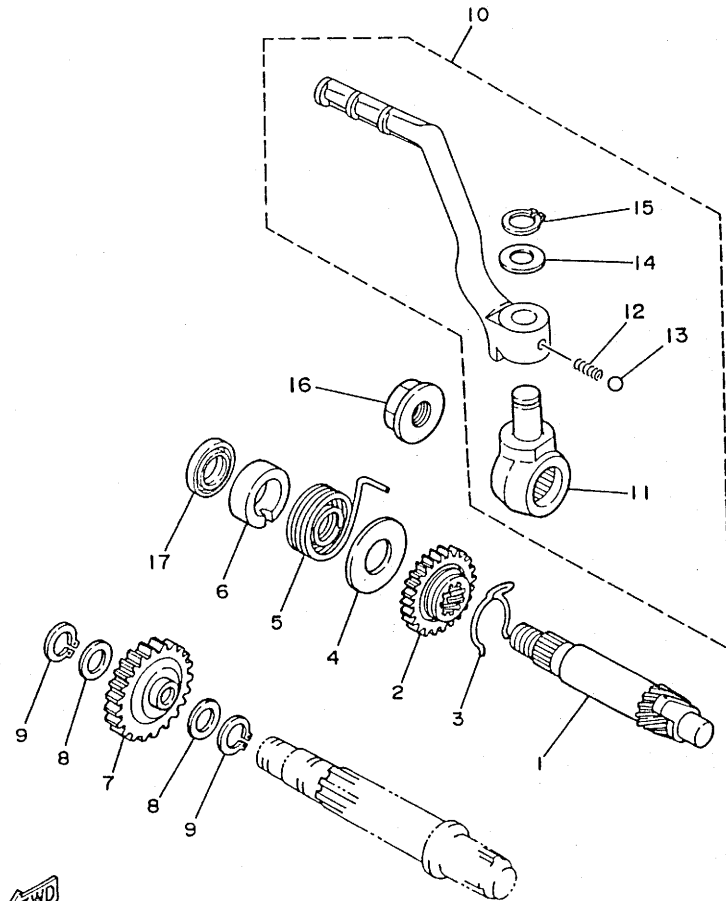

3XP1010-1110

C2

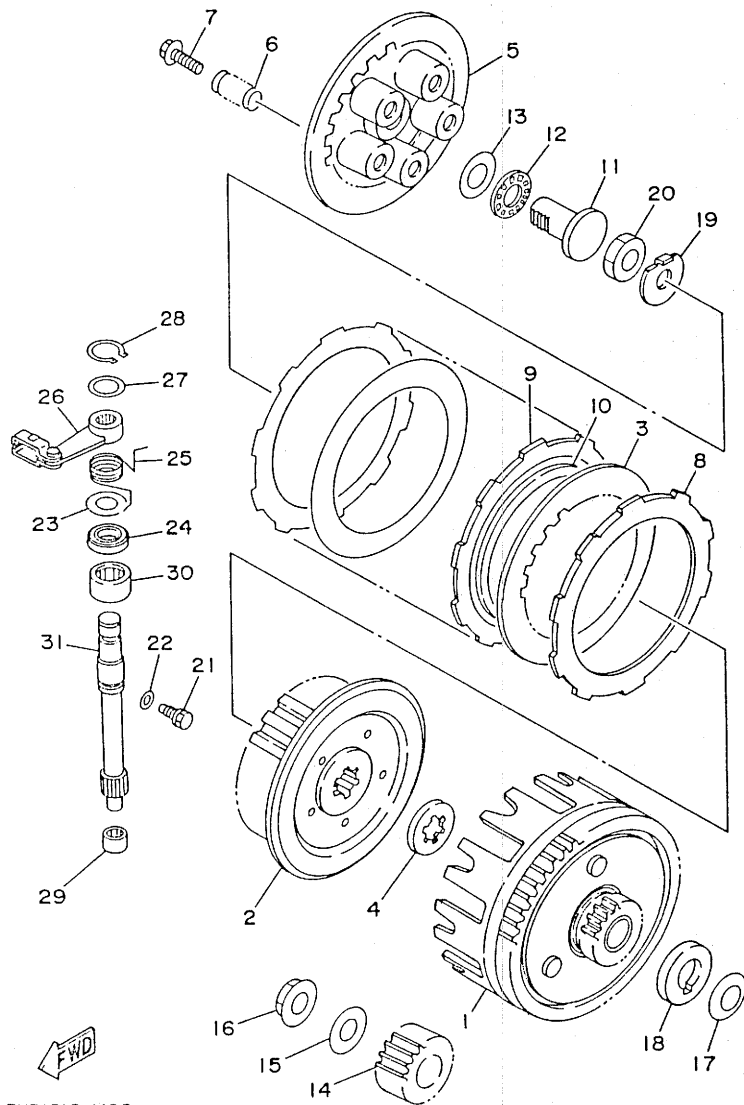

3XP1010-1120

FIG. 11 CLUTCH

REF. NO.	PART NO.	DESCRIPTION	Q'TY	REMARKS
1	3XP-16150-00	PRIMARY DRIVEN GEAR COMP.	1	
2	2TV-16371-00	BOSS, clutch	1	
3	1V1-16324-00	PLATE, clutch 1	6	
4	2TV-16154-00	PLATE, thrust 1	1	
5	3XP-16351-00	PLATE, pressure 1	1	
6	90501-20568	SPRING, compression	5	
7	90119-05001	BOLT, with washer	5	
8	21V-16321-00	PLATE, friction	6	
9	1HX-16331-00	PLATE, friction 2	1	
10	3BN-16383-00	SPRING, clutch boss	1	
11	3LD-1637A-00	ROD PUSH ASSY	1	
12	93340-21505	BEARING, thrust	1	
13	90201-150H2	WASHER, plate	1	
14	3RR-16111-00	GEAR, primary drive	1	
15	90201-120E8	WASHER, plate	1	
16	90179-12244	NUT	1	
17	90208-18046	WASHER, conical spring	1	
18	90201-180P2	WASHER, plate	1	
19	90215-12271	WASHER, lock	1	
20	90170-12370	NUT	1	
21	90109-06418	BOLT	1	
22	90430-06014	GASKET	1	
23	90201-12474	WASHER, plate	1	
24	93102-15212	OIL SEAL	1	
25	90508-14767	SPRING, torsion	1	
26	4H7-16340-00	PUSH LEVER ASSY	1	
27	90201-10119	WASHER, plate	1	
28	99009-10400	CIRCLIP	1	

C3

FIG. 11 CLUTCH

REF. NO.	PART NO.	DESCRIPTION	Q'TY	REMARKS
29	93315-10838	BEARING, cylindrical	1	
30	93315-31502	BEARING, cylindrical	1	
31	3JD-16382-00	AXLE, push lever	1	

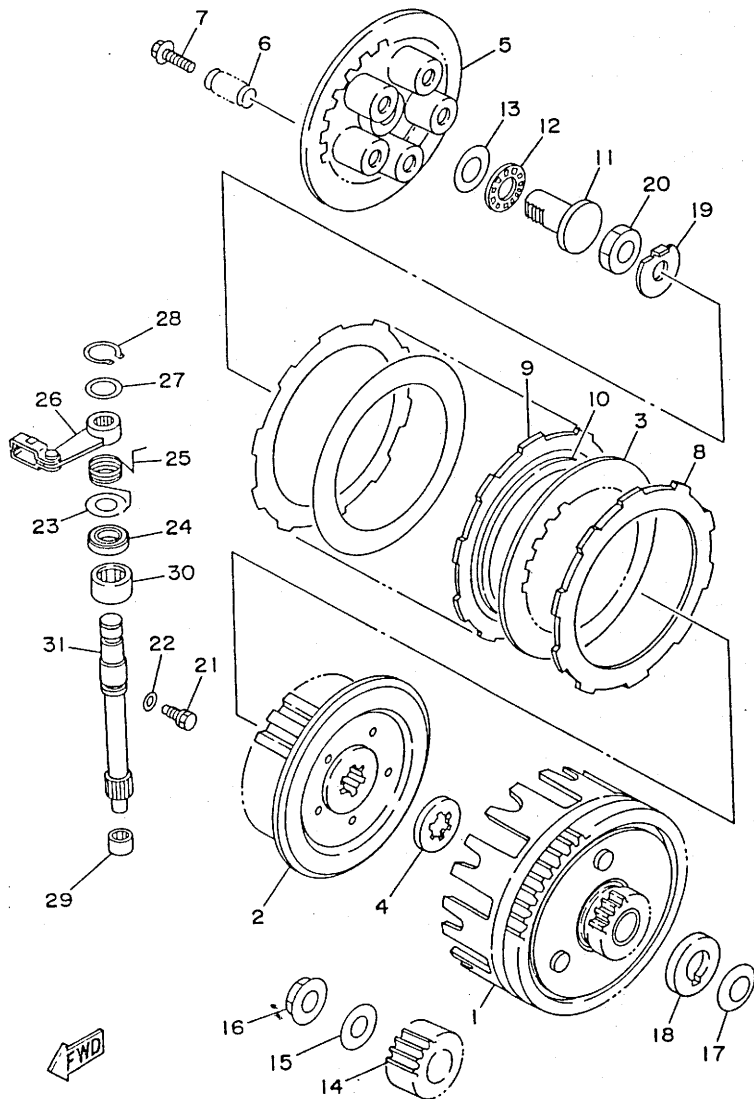

3XP1010-1120

C4

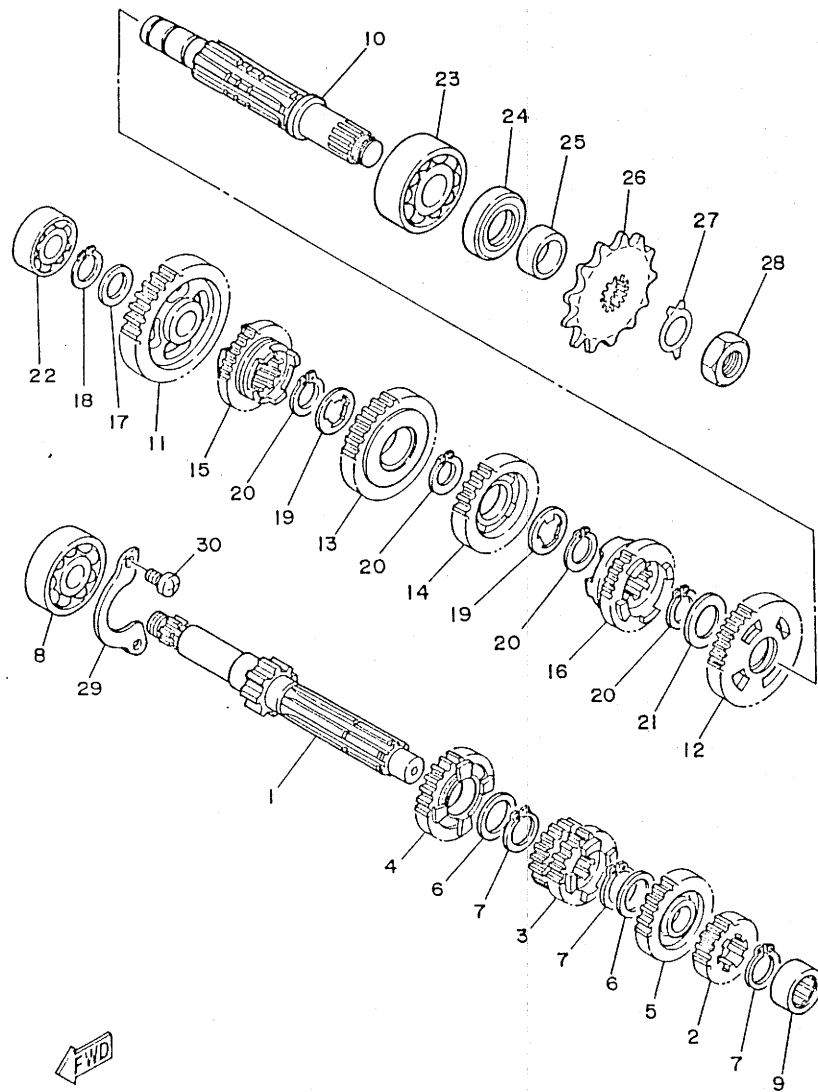

FIG. 12 TRANSMISSION

REF. NO.	PART NO.	DESCRIPTION	Q'TY	REMARKS
1	4BF-17411-00	AXLE, main (13T)	1	
2	3BN-17121-00	GEAR, 2nd pinion (16T)	1	
3	3BN-17131-01	GEAR, 3rd pinion	1	
4	3BN-17151-01	GEAR, 5th pinion (23T)	1	
5	3BN-17161-02	GEAR, 6th pinion	1	
6	90201-20266	WASHER, plate (1.0T)	2	
7	93410-20038	CIRCLIP	3	
8	93306-20431	BEARING (B6204Z)	1	
9	93311-31567	BEARING, cylindrical	1	
10	3BN-17421-00	AXLE, drive	1	
11	4BF-17211-00	GEAR, 1st wheel (32T)	1	
12	3BN-17221-00	GEAR, 2nd wheel (30T)	1	
13	3BN-17231-01	GEAR, 3rd wheel	1	
14	3XP-17241-00	GEAR, 4th wheel	1	
15	3BN-17251-02	GEAR, 5th wheel	1	
16	3XP-17261-00	GEAR, 6th wheel	1	
17	90201-154E8	WASHER, plate	1	
18	99009-15400	CIRCLIP	1	
19	90209-18135	WASHER	2	
20	93410-22039	CIRCLIP	4	
21	90201-22555	WASHER, plate	1	
22	93306-20211	BEARING	1	
23	93306-30438	BEARING	1	
24	93102-26042	OIL SEAL	1	
25	90387-205W8	COLLAR	1	
26	9383A-13031	SPROCKET,drive 13t (2HG1746130)	1	
27	90215-20283	WASHER, lock	1	
28	90179-16613	NUT	1	



3XP1010-1130

C5

FIG. 12 TRANSMISSION

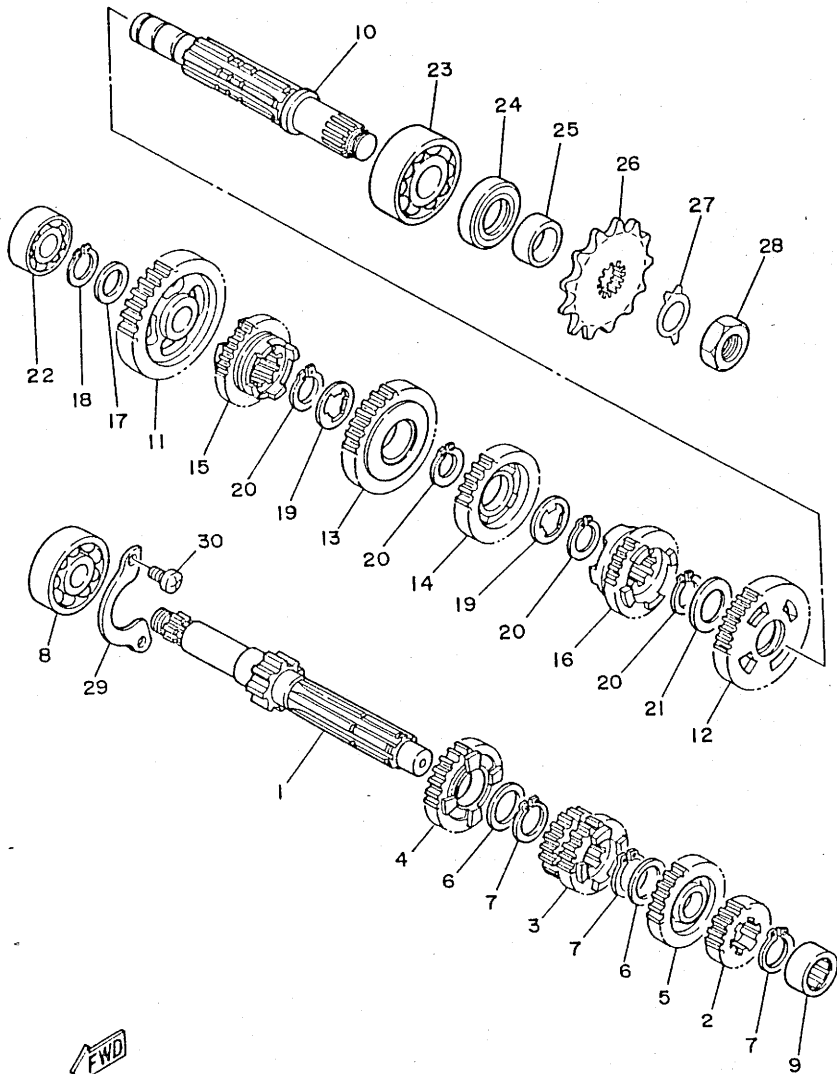

REF. NO.	PART NO.	DESCRIPTION	Q'TY	REMARKS
29	4BF-17471-00	PLATE, cover	1	
30	98501-06012	SCREW, pan head	2	



3XP1010-1130

C6

FIG. 13 SHIFT CAM. FORK

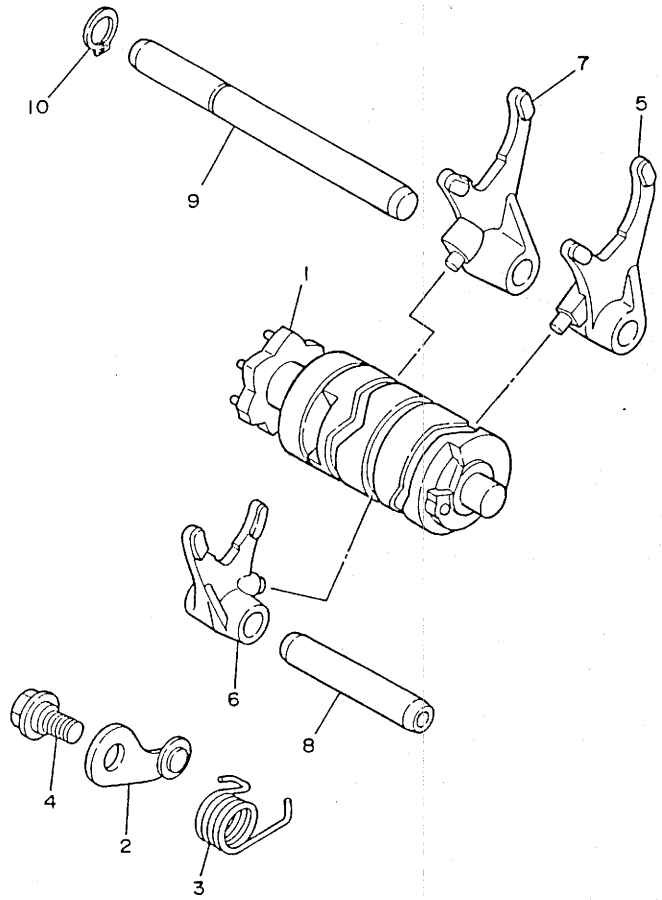

REF. NO.	PART NO.	DESCRIPTION	Q'TY	REMARKS
1	3XP-18540-00	SHIFT CAM ASSY	1	
2	3BN-18140-00	STOPPER LEVER ASSY	1	
3	90508-26561	SPRING, torsion	1	
4	90109-063F7	BOLT	1	
5	55K-18511-01	FORK, shift 1	1	
6	2RH-18512-00	FORK, shift 2	1	
7	55K-18513-00	FORK, shift 3	1	
8	55K-18531-00	BAR, shift fork guide 1	1	
9	3BN-18535-00	BAR, shift fork guide 2	1	
10	99009-10400	CIRCLIP	1	



3BN300-8150

C7

FIG. 14 SHIFTER

REF. NO.	PART NO.	DESCRIPTION	Q'TY	REMARKS
1	10W-18101-03	SHIFT SHAFT ASSY	1	
2	93101-12060	OIL SEAL	1	
3	90508-32553	SPRING, torsion	1	
4	99006-10600	CIRCLIP	1	
5	3XP-18110-00	SHIFT PEDAL ASSY	1	
6	1W6-18113-00	.COVER, shift pedal	1	
7	97011-06020	BOLT	1	

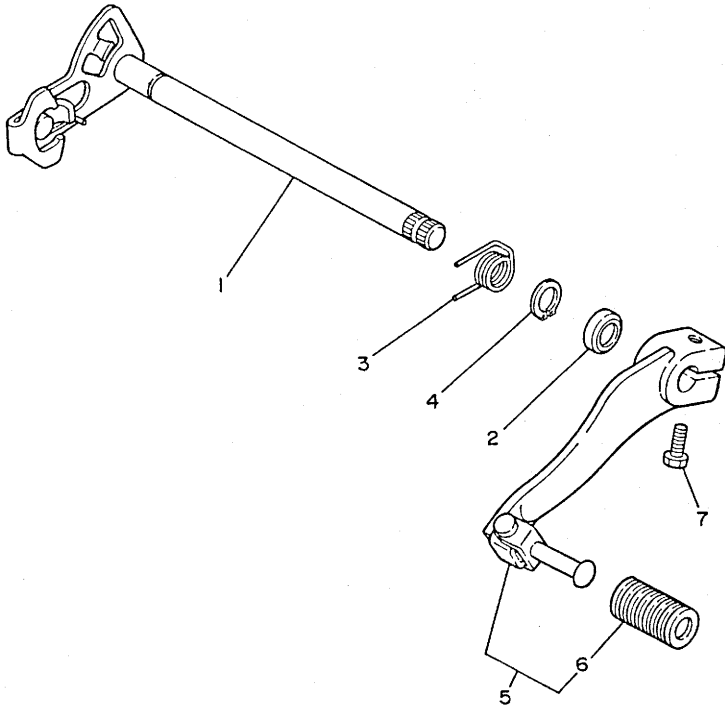

3BN300-8160

C8

(MC-92001-012)

SEE FIG 17

FIG. 15 FRAME

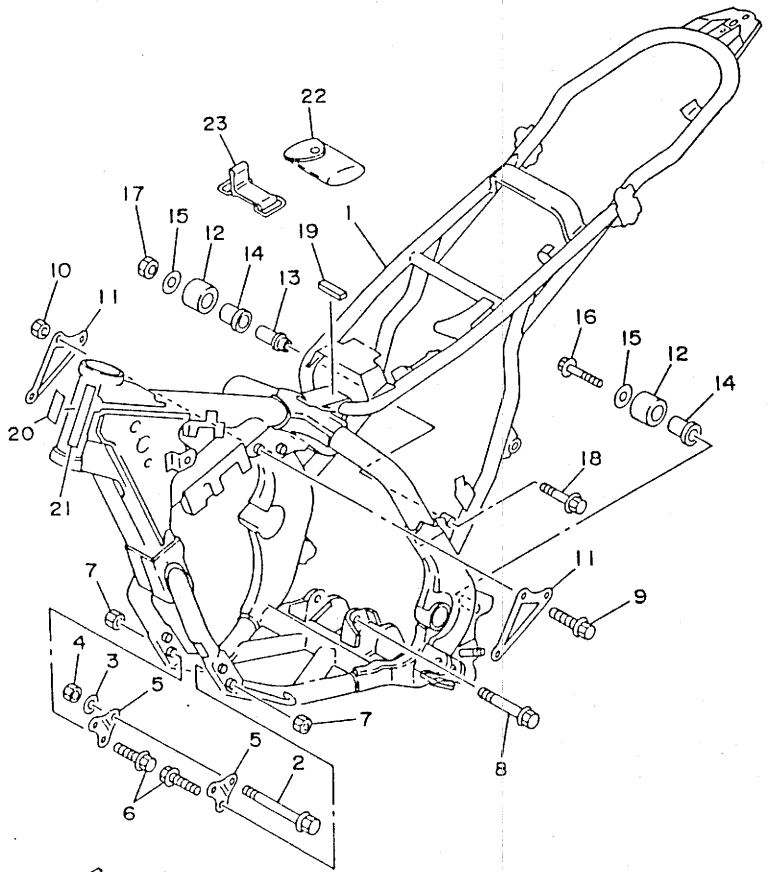

REF. NO.	PART NO.	DESCRIPTION	Q'TY	REMARKS
1	4BF-21110-00-UJ	FRAME COMP.	1	RADICAL WHITE
2	90105-10645	BOLT, washer based	1	
3	90201-100E9	WASHER, plate	1	
4	90185-10060	NUT, self-locking	1	
5	3XP-21415-00	BRACKET, front upper 1	2	
6	90105-08663	BOLT, washer based	4	
7	95611-08200	NUT, self-locking	4	
8	90105-08646	BOLT, washer based	1	
9	90105-08663	BOLT, washer based	3	
10	95611-08200	NUT, self-locking	3	
11	3XP-21425-00	BRACKET, rear upper 1	2	
12	30X-22178-00	TENSIONER	2	
13	2K7-2148A-00	SHAFT	1	
14	10V-22184-00	BUSH	2	
15	90201-08753	WASHER, plate	2	
16	95023-08050	BOLT	1	
17	95611-08100	NUT, u	1	
18	95023-08012	BOLT	1	
19	56J-21747-00	DAMPER	1	
20	4BF-2179X-00	PLATE, epa u50	1	FOR USA
21	1JK-21268-00	SEAL	1	
22	3XP-28100-00	TOOL KIT	1	
23	1KH-82131-00	BAND, battery	1	

4BF1100-2150

C9

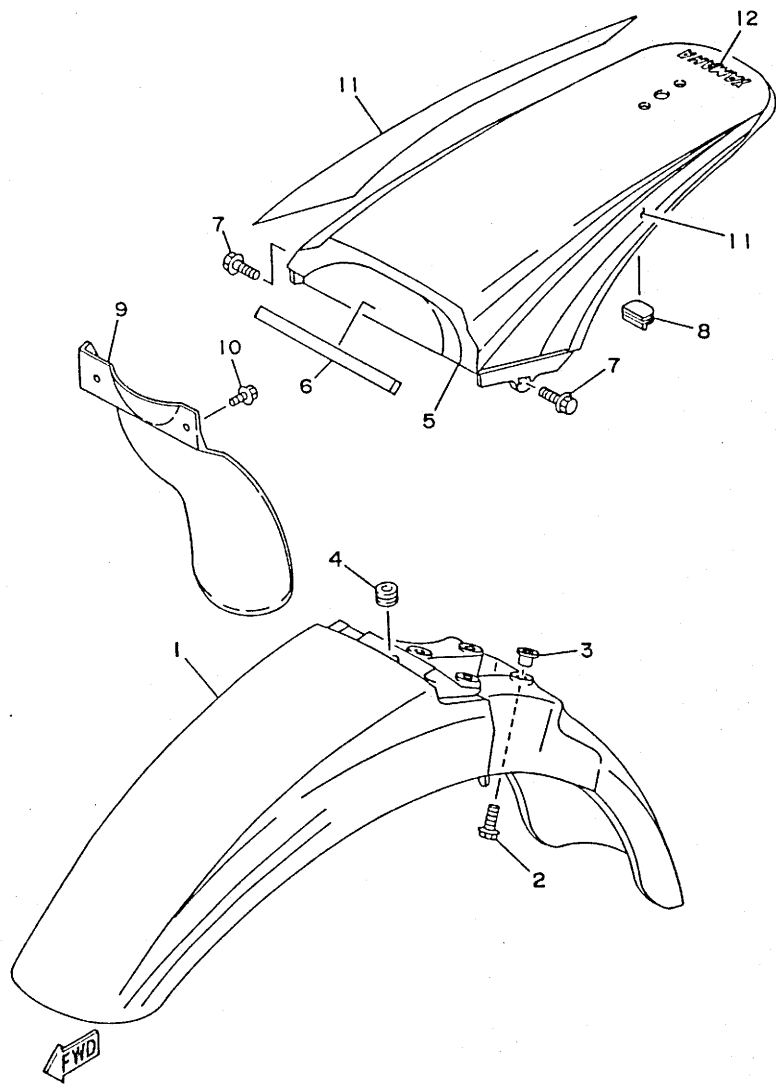
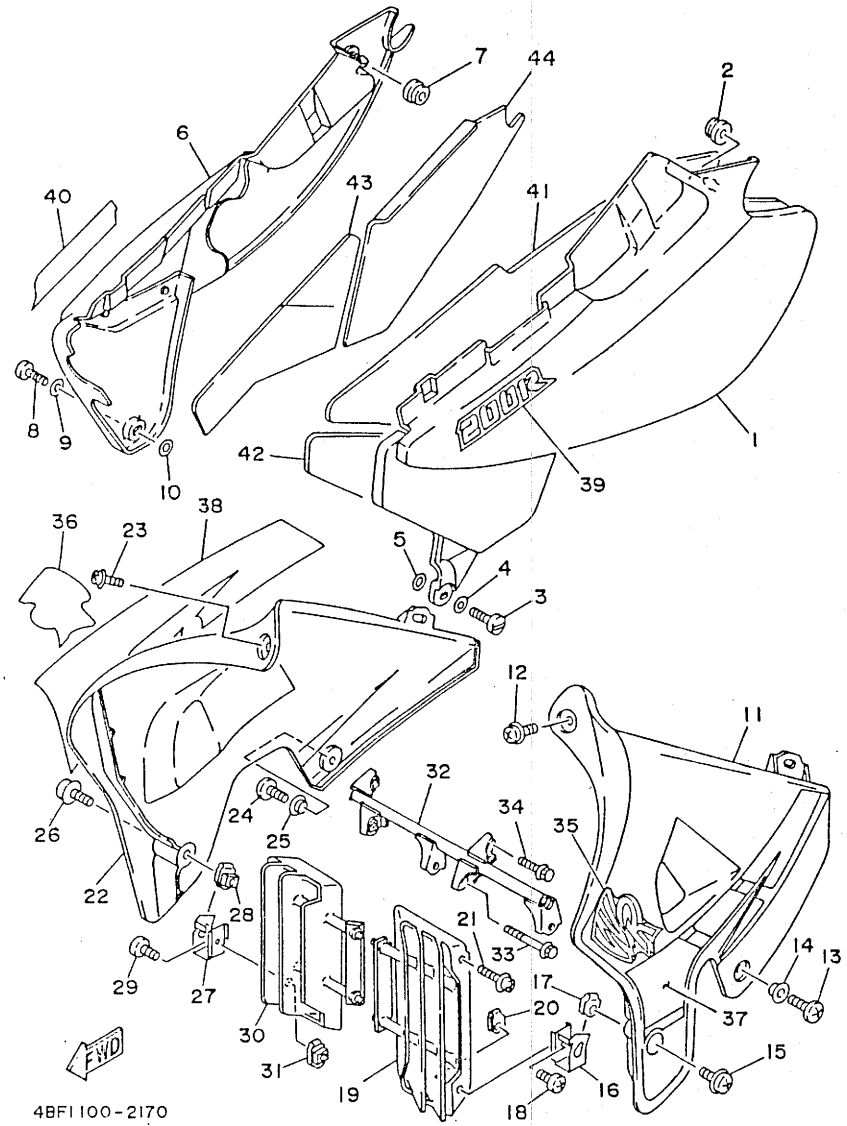

FIG. 16 FENDER

REF. NO.	PART NO.	DESCRIPTION	Q'TY	REMARKS
1	3XP-21511-00	FENDER, front	1	
2	90119-06097	BOLT, with washer	4	
3	90387-062V8	COLLAR	4	
4	90480-13398	GROMMET	1	
5	4BF-21611-00	FENDER, rear	1	
6	3XP-21639-00	DAMPER 2	1	
7	90119-06207	BOLT, with washer	2	
8	90480-16185	GROMMET	1	
9	39X-21642-00	GUARD, flap	1	
10	90119-06194	BOLT, with washer	2	
11	3XP-2165A-11	GRAPHIC SET, rear fender	1	
12	99244-00020	EMBLEM, yamaha	1	

4BF1100-2160

FIG. 17 SIDE COVER MC-92001-2/2



48F1100-2170

REF. NO.	PART NO.	DESCRIPTION	Q'TY	REMARKS
1	3XP-21711-00	COVER, side 1 → 99999-02255		
2	90480-13398	GROMMET	1	
3	90149-06223	SCREW	1	
4	90201-062A8	WASHER, plate	1	
5	4U5-2176E-00	PLATE	1	
6	3XP-21721-00 →	COVER, side 2 99999-02256		
7	90480-13398	GROMMET	1	
8	90149-06223	SCREW	1	
9	90201-062A8	WASHER, plate	1	
10	4U5-2176E-00	PLATE	1	
11	4BF-21731-00	COVER, side 3	1	
12	90159-06160	SCREW, with washer	1	
13	90154-05063	SCREW, binding	2	
14	90387-062M9	COLLAR	2	
15	90159-05183	SCREW, with washer	1	
16	4BF-2138K-01	BRACKET, 1	1	
17	22W-21791-00	NUT	1	
18	90157-05079	SCREW, pan head	1	
19	3XJ-2172A-00	PANEL 1	1	
20	22W-21791-00	NUT	2	
21	90159-05183	SCREW, with washer	1	
22	4BF-21741-00	COVER, side 4	1	
23	90159-06160	SCREW, with washer	1	
24	90154-05063	SCREW, binding	2	
25	90387-062M9	COLLAR	2	
26	90159-05183	SCREW, with washer	1	
27	4BF-2138L-00	BRACKET 2	1	
28	22W-21791-00	NUT	1	

C11

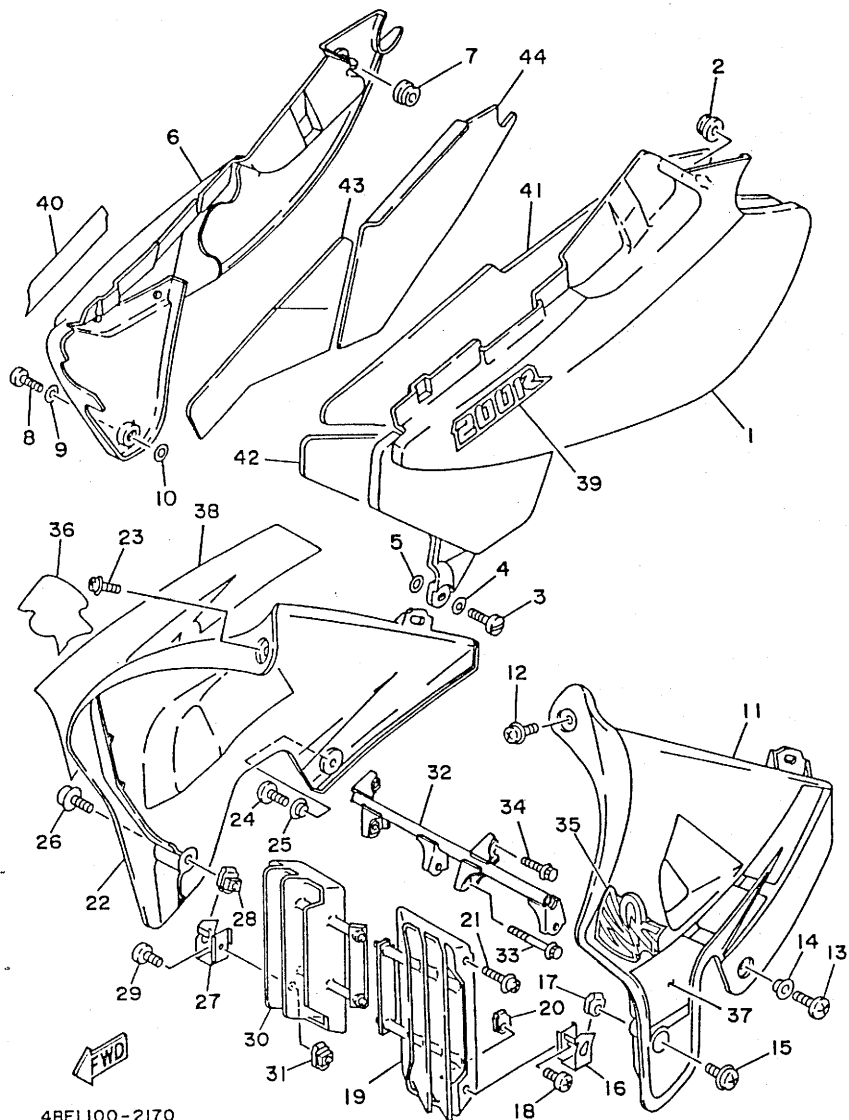

48F1100-2170

FIG. 17 SIDE COVER

REF. NO.	PART NO.	DESCRIPTION	Q'TY	REMARKS
29	90157-05079	SCREW, pan head	1	
30	3XJ-2172F-00	PANEL 2	1	
31	22W-21791-00	NUT	2	
32	3XP-2174F-00	GUARD, radiator	1	
33	95023-08045	BOLT	1	
34	95023-08012	BOLT	1	
35	4BF-21781-00	EMBLEM 1	1	
36	4BF-21781-00	EMBLEM 1	1	
37	3XP-2173E-11	GRAPHIC 1	1	
38	3XP-2173L-11	GRAPHIC SET 1	1	
39	3XP-21782-10	EMBLEM 2	1	
40	3XP-21782-10	EMBLEM 2	1	
41	3XP-21746-00	DAMPER	1	
42	3XP-21747-00	DAMPER	1	
43	3XP-2174A-00	INSULATOR, side cover	1	
44	3XP-2174T-00	INSULATOR, side cover 2	1	

FIG. 18 OIL TANK

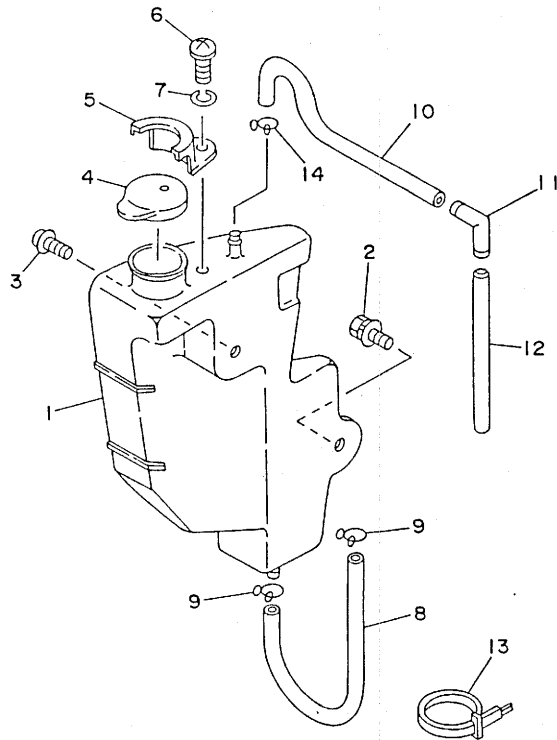

REF. NO.	PART NO.	DESCRIPTION	Q'TY	REMARKS
1	3XP-21871-00	TANK, recovery	1	
2	90119-06205	BOLT, with washer	1	
3	90159-05183	SCREW, with washer	1	
4	1AA-21815-00	CAP	1	
5	3MA-2172N-00	BRACKET 4	1	
6	98506-06010	SCREW, pan head	1	
7	92906-06100	WASHER, spring	1	
8	3XP-25895-50	HOSE, reservoir	1	
9	90467-08003	CLIP	2	
10	3XP-2589E-00	HOSE	1	
11	26H-21828-00	ELBOW	1	
12	90445-094F0	HOSE	1	
13	341-26397-01	BAND	1	
14	90467-08003	CLIP	1	



4BF1100-2180

C13

FIG. 19 REAR ARM

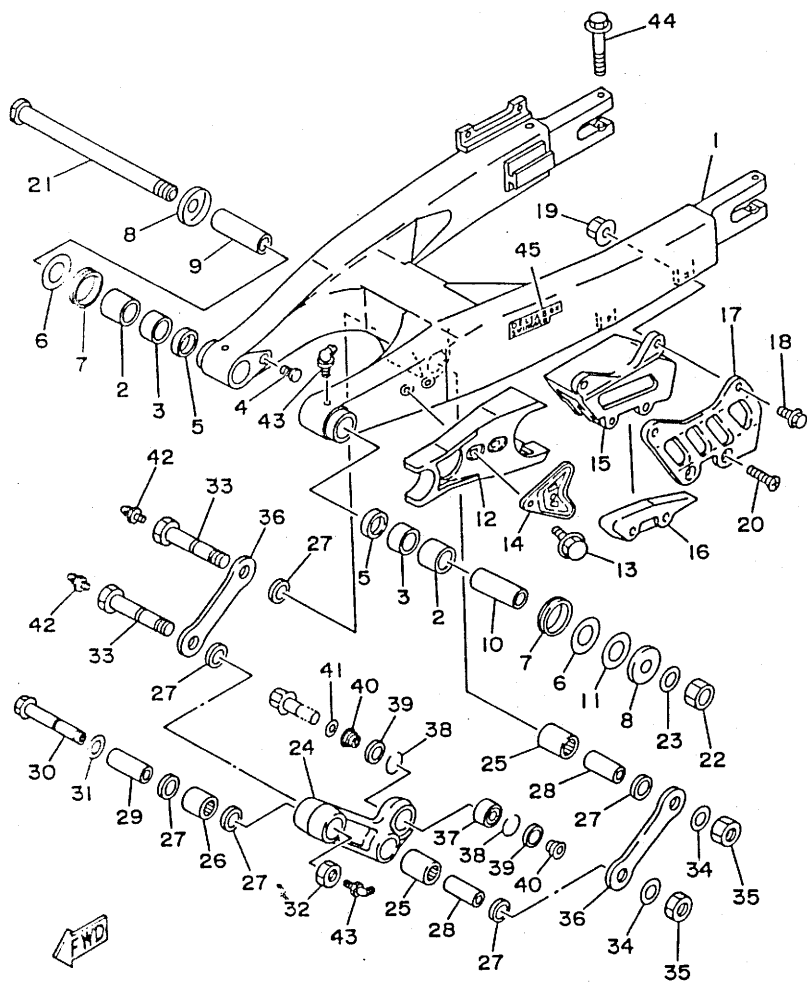

REF. NO.	PART NO.	DESCRIPTION	Q'TY	REMARKS
1	4BF-22110-00-T9	REAR ARM COMP.	1	COMPETITION SILVER
2	93317-32231	BEARING, cylindrical	2	
3	90380-22111	BUSH, solid	2	
4	90338-10150	PLUG	2	
5	93106-22019	OIL SEAL (DC 22-28-8)	2	
6	90201-254H8	WASHER, plate	2	
7	93108-35004	OIL SEAL (35-41-8)	2	
8	30X-2219X-00	COVER	2	
9	90387-166X2	COLLAR	1	
10	90387-166X3	COLLAR	1	
11	90201-251F6	WASHER, plate (0.3T)	1	UN
12	3XP-22151-00	SEAL, guard	1	
13	95821-06014	BOLT, flange	2	
14	3JD-22156-00	WASHER, plate	1	
15	3XP-22199-00	SUPPORT, chain	1	
16	3JD-22147-00	PROTECTOR, chain	1	
17	3JD-22128-00	COVER, thrust 1	1	
18	95811-06025	BOLT, flange	2	
19	95701-06500	NUT, flange	2	
20	98701-06050	SCREW, flat head	2	
21	11X-22141-00	SHAFT, pivot	1	
22	90185-16127	NUT, self-locking	1	
23	90201-164H4	WASHER, plate	1	
24	3XP-2217A-00	ARM, relay	1	
25	93315-22046	BEARING, cylindrical	2	
26	93315-22046	BEARING, cylindrical	1	
27	93109-20029	OIL SEAL	6	
28	90387-166X0	COLLAR	2	

4BF11CO-2190

C14

FIG. 19 REAR ARM

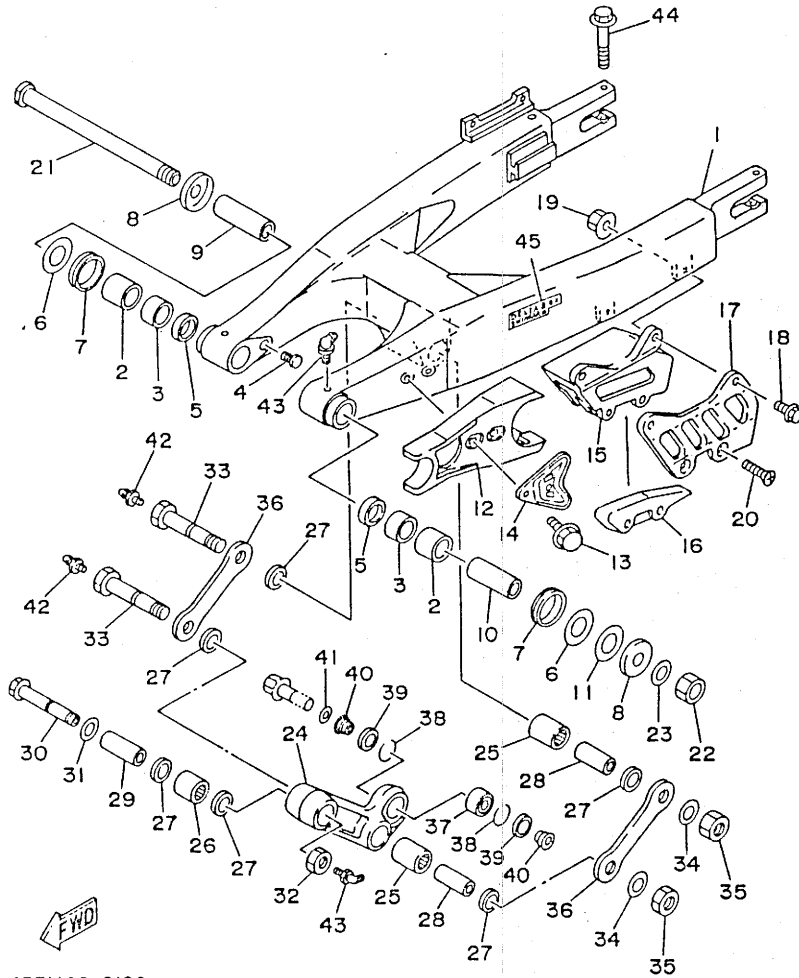

REF. NO.	PART NO.	DESCRIPTION	Q'TY	REMARKS
29	90387-166X1	COLLAR	1	
30	95811-10016	BOLT, flange	1	
31	90201-106F2	WASHER, plate	1	
32	90179-10616	NUT	1	
33	90401-14147	BOLT, union	2	
34	90201-160F6	WASHER, plate	2	
35	90185-14070	NUT, self-locking	2	
36	3XP-2217F-00	ROD, connecting 1	2	
37	93399-99935	BEARING	1	
38	93440-30113	CIRCLIP	2	
39	3XJ-22475-00	SEAL, dust	2	
40	90387-103X9	COLLAR	2	
41	90201-08759	WASHER, plate	1	
42	93700-06004	NIPPLE, grease	2	
43	93700-06005	NIPPLE, grease	3	
44	95811-06045	BOLT, flange	2	
45	3XJ-2218A-00	EMBLEM, rear arm	2	

4BF1100-2190



FIG. 20 REAR SUSPENSION

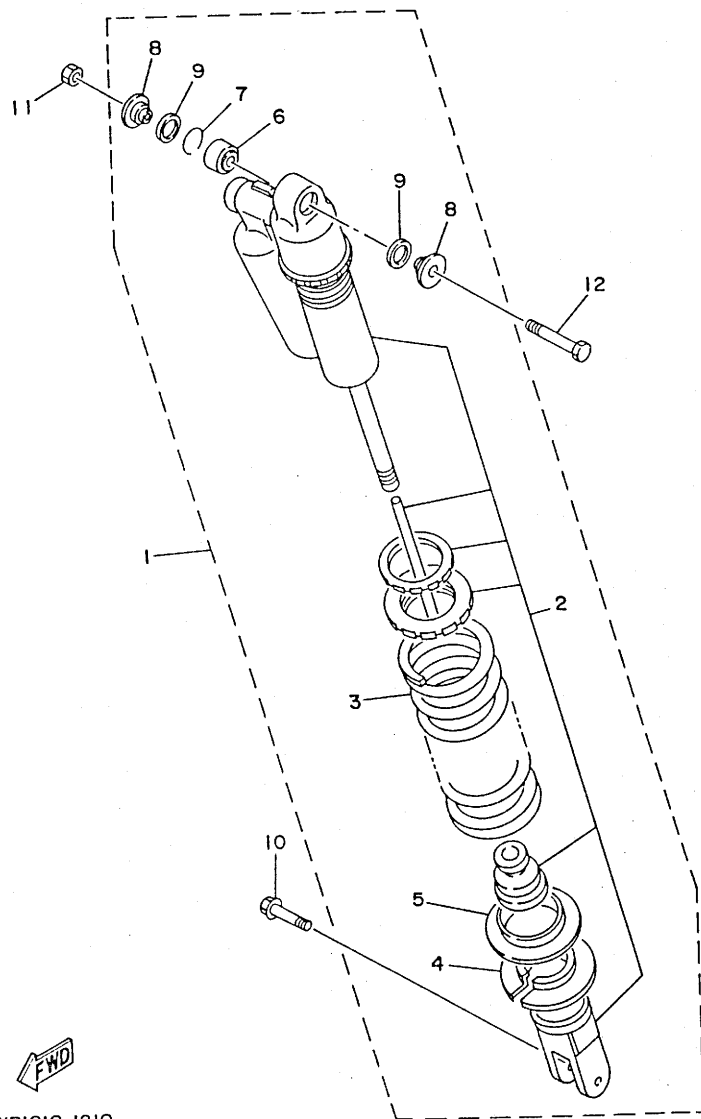

REF. NO.	PART NO.	DESCRIPTION	Q'TY	REMARKS
1	4BF-22210-00-P0	SHOCK ABSORBER ASSY, rear	1	UR VIVID MAGENTA SOLID 2 FOR USA/OCEANIA
	4BF-22210-10-P0	SHOCK ABSORBER ASSY, rear	1	UR VIVID MAGENTA SOLID 2 FOR EUROPE
2	4BF-22201-00	.DAMPER SUB ASSY	1	UR FOR USA/OCEANIA
	4BF-22201-10	.DAMPER SUB ASSY	1	UR FOR EUROPE
3	4BF-22212-00-P0	.SPRING	1	VIVID MAGENTA SOLID 2
4	3XP-22214-00	.GUIDE, spring 1	1	
5	3XP-22224-00	.GUIDE, spring 2	1	
6	93399-99934	.BEARING	1	
7	93440-30113	.CIRCLIP	1	
8	90387-100Y3	.COLLAR	2	
9	23X-22211-00	.COVER	2	
10	90105-10614	BOLT, washer based	1	
11	95611-10200	NUT, self-locking	1	
12	3SP-22241-00	BOLT 1	1	



3XP1010-1210

D2

FIG. 21 STEERING

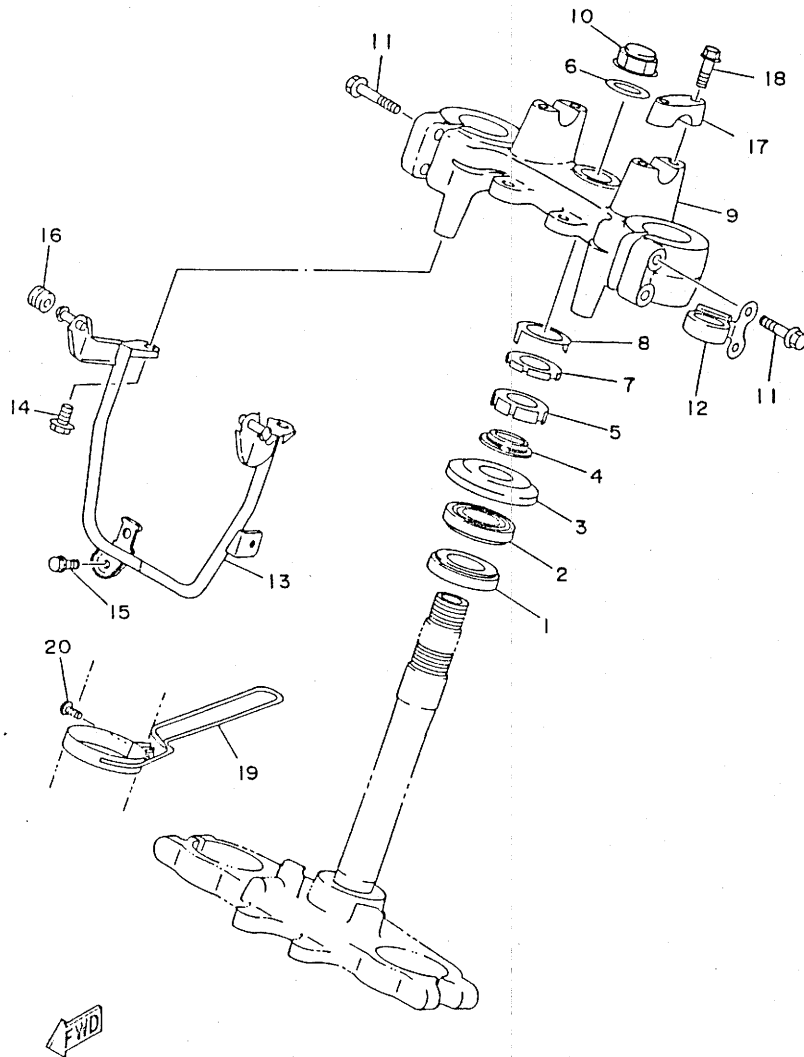

REF. NO.	PART NO.	DESCRIPTION	Q'TY	REMARKS
1	93332-00067	BEARING	1	
2	93332-00068	BEARING	1	
3	3XP-23416-00	COVER, ball race 2	1	
4	3XP-23462-00	SEAL, steering	1	
5	90179-25614	NUT	1	
6	90202-26142	WASHER, plate	1	
7	90179-25615	NUT	1	
8	26H-23418-01	WASHER, special	1	
9	4BF-23435-01-35	CROWN, handle	1	SILVER
10	90176-22050	NUT, crown	1	
11	95026-08040	BOLT, flange	4	
12	3XP-23389-00	GUIDE, cable	1	
13	4BF-23174-00	STAY, headlight	1	
14	95023-06012	BOLT	2	
15	91001-06012	BOLT, flange	1	
16	90480-12053	GROMMET	2	
17	1E6-23441-10-35	HOLDER, handle upper	2	SILVER
18	95023-08035	BOLT	4	
19	3XP-23318-00	HOLDER, cable 1	1	
20	98501-05012	SCREW, pan head	1	

4BF1100-2210

D3

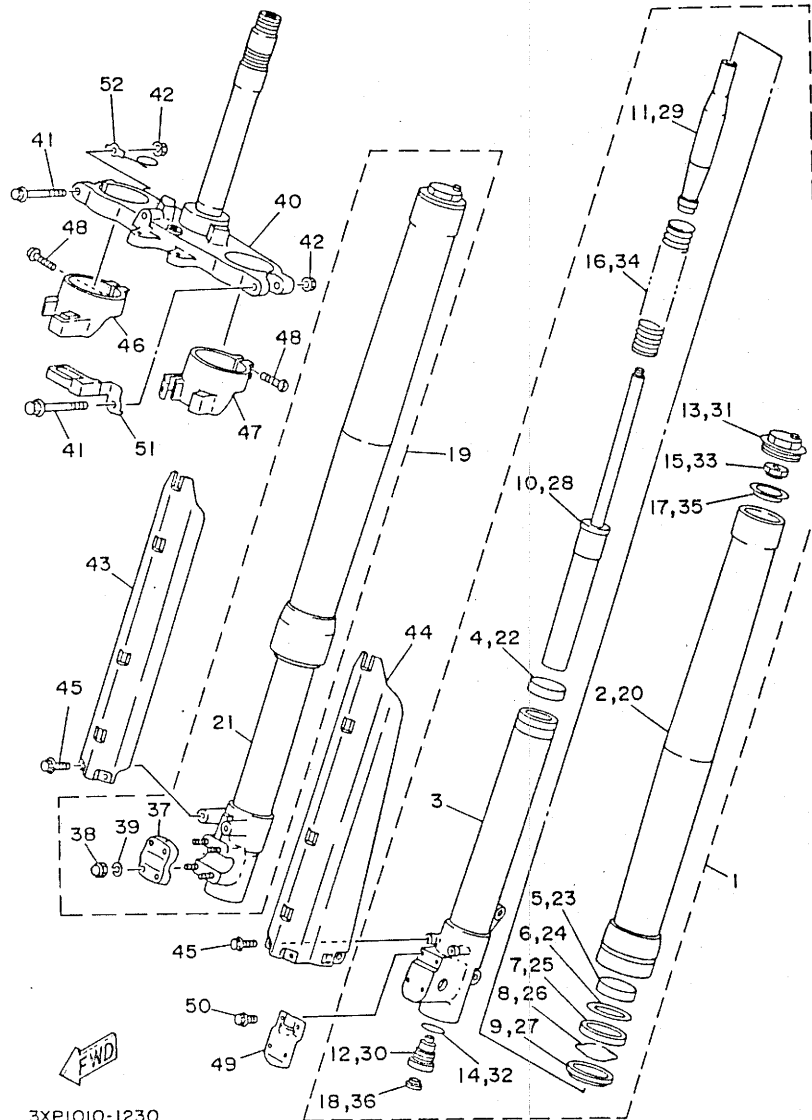

3XPIO10-1230

FIG. 22 FRONT FORK

REF. NO.	PART NO.	DESCRIPTION	Q'TY	REMARKS
29	3XP-23142-00	.SEAT, spring upper	1	
30	4BF-2316A-00	.VALVE COMP.	1	
31	3XP-23111-00	.BOLT, cap	1	
32	2HH-23158-L0	.GASKET	1	
33	3XP-23778-00	.NUT	1	
34	4BF-23141-00	.SPRING, front fork	1	
35	3SP-23143-L0	.SEAT, spring lower	1	
36	55Y-2312G-M0	.PLUG	1	
37	3XJ-23167-L0	.HOLDER, axle	1	
38	5Y3-23393-00	.NUT, special	4	
39	92990-06100	.WASHER, spring	4	
40	3XP-23340-00	UNDER BRACKET COMP.	1	
41	3XP-23346-00	BOLT 1	2	
42	95701-10500	NUT, flange	2	
43	3XP-2314J-L0	PROTECTOR COMP., 2	1	
44	3SP-2314H-L0	PROTECTOR COMP., 1	1	
45	3SP-23356-L0	BOLT 2	6	
46	3SP-2314G-L0	PROTECTOR GUIDE COMP., 2	1	
47	3SP-2314F-L0	PROTECTOR GUIDE COMP., 1	1	
48	4V4-23194-L0	SCREW, boot band	4	
49	3SP-2314E-L0	COVER, hose	1	
50	3SP-23346-L0	BOLT 1	4	
51	3XP-23318-10	HOLDER, cable 1	1	
52	3XP-23389-10	GUIDE, cable	1	

D5

FIG. 23 FUEL TANK

REF. NO.	PART NO.	DESCRIPTION	Q'TY	REMARKS
1	4BF-24110-00	FUEL TANK COMP.	1	
2	1UY-24610-00	CAP ASSY	1	
3	90445-09304	HOSE	1	
4	90468-15064	CLIP	1	
5	3XJ-21717-00	DAMPER, side cover	2	
6	1LX-24181-00	DAMPER, locating 1	1	
7	4BF-24173-00	BAND, tank fitting 1	1	
8	98980-06020	SCREW, bind	1	
9	90149-06165	SCREW	1	
10	24X-24144-00	HOLDER, damper	2	
11	95021-06014	BOLT, flange	4	
12	90480-18354	GROMMET	2	
13	90119-06206	BOLT, with washer	2	
14	90387-06387	COLLAR	2	
15	5X6-2412F-00	BRACKET, seat	1	
16	98501-06012	SCREW, pan head	2	
17	92990-06100	WASHER, spring	2	
18	3BN-24500-00	FUEL COCK ASSY 1	1	
19	4X8-24512-00	.O-RING	1	
20	98503-03008	.SCREW, pan head	2	
21	90149-06011	SCREW	2	
22	90202-05193	WASHER, plate	2	
23	3XP-24311-00	PIPE, fuel 1	1	
24	90467-10008	CLIP	1	
25	90467-08003	CLIP	1	

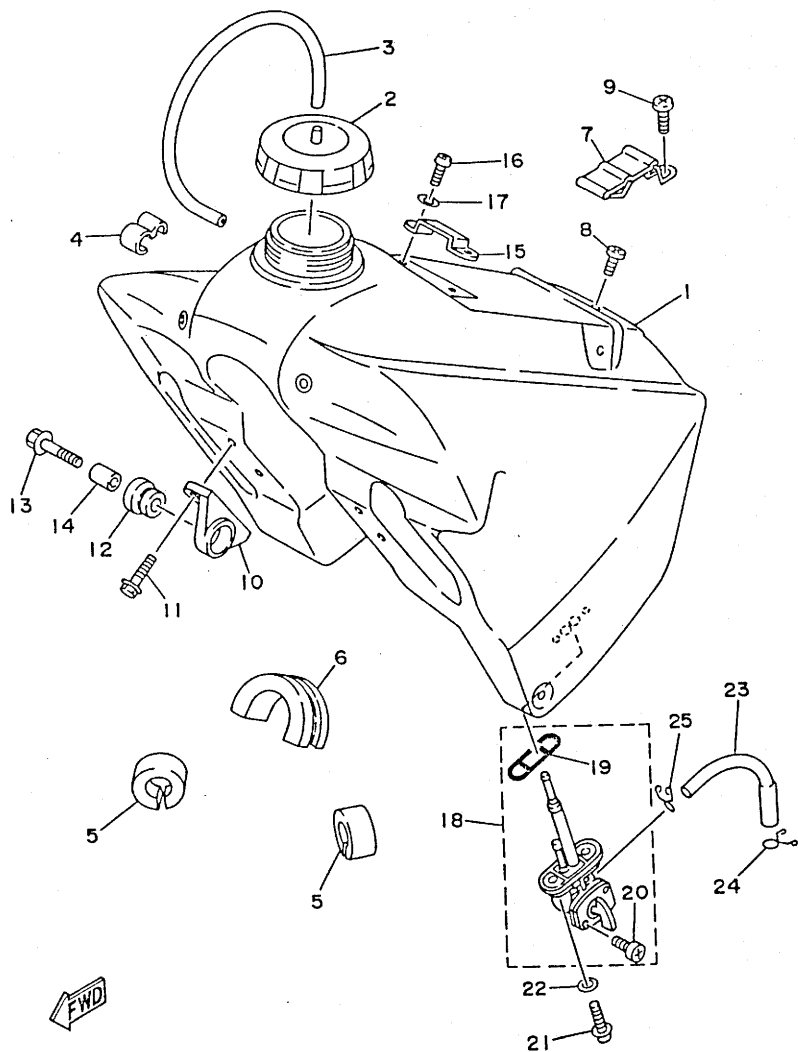

4BF1100-2230

D6

FIG. 24 SEAT

REF. NO.	PART NO.	DESCRIPTION	Q'TY	REMARKS
1	4BF-24770-00	SEMI-DOUBLE SEAT ASSY	1	
2	4BF-24731-00	.COVER, seat	1	
3	509-24724-00	.DAMPER, seat	2	
4	90119-06043	BOLT, with washer	2	

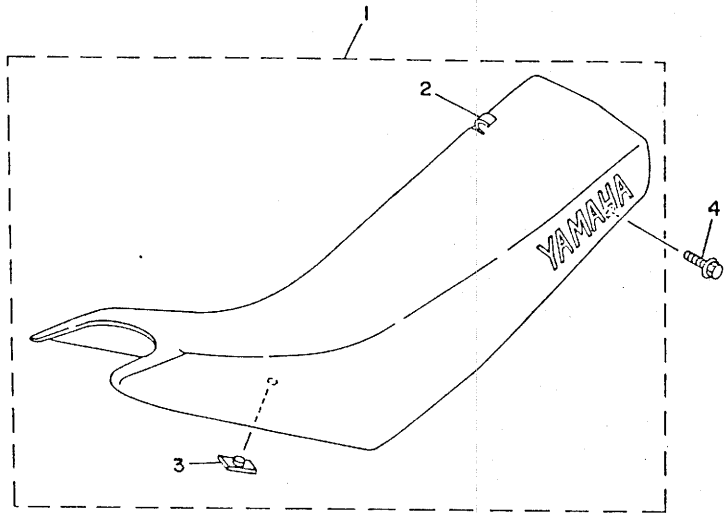

4BF1100-2240

D7

FIG. 25 FRONT WHEEL

REF. NO.	PART NO.	DESCRIPTION	Q'TY	REMARKS
1	3XP-25111-00-35	HUB, front	1	SILVER
2	93306-20209	BEARING (B6202)	2	
3	90560-15290	SPACER	1	
4	93102-20281	OIL SEAL (SD 20-35-5)	1	
5	94416-21430	RIM (1.60-21)	1	
6	55U-25104-00	SPOKE SET, front	1	
7	94108-216U5	TIRE (80/100-21 51H D704F P)	1	DUNLOP
8	94227-21123	TUBE (2.75-21)	1	BRIDGESTONE
9	94307-21145	BAND, rim (70-80/100-21)	1	DUNLOP
10	5X2-25394-00	SPACER, bead	1	
11	90387-15600	COLLAR	1	
12	322-25118-00	COVER, hub dust	1	
13	55U-25181-01	AXLE, wheel	1	
14	3XP-25190-00	GEAR UNIT ASSY	1	

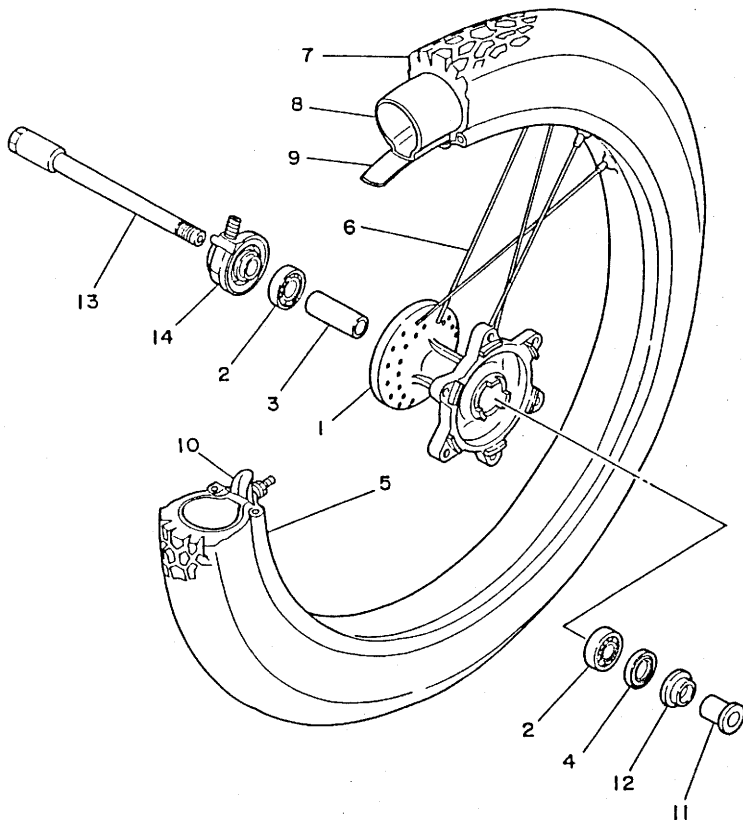

FWD

4BF1100-2250

D8

FIG. 26 FRONT BRAKE CALIPER

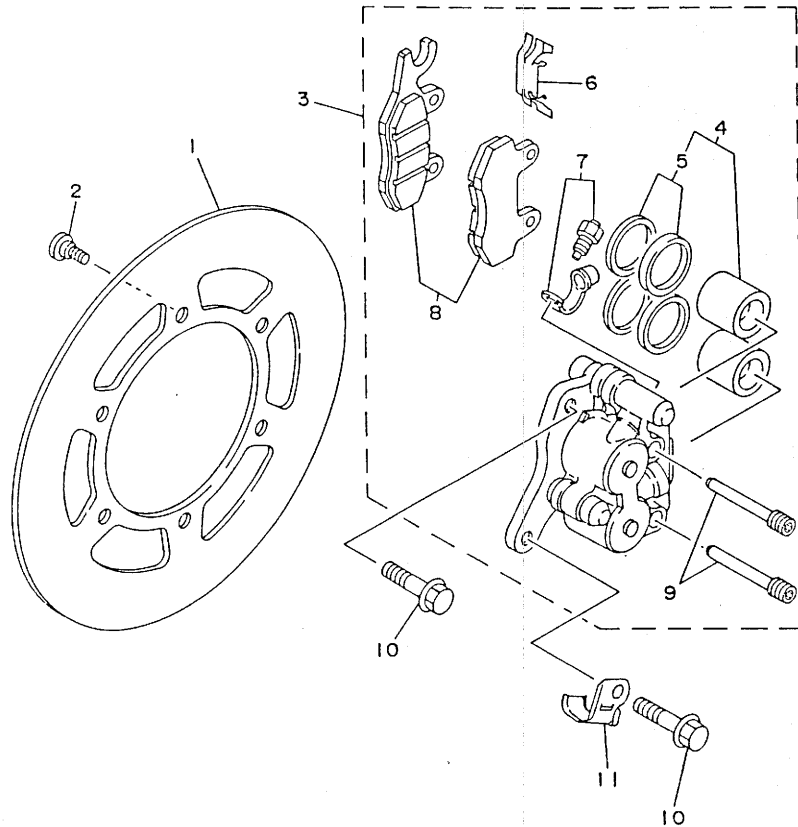

REF. NO.	PART NO.	DESCRIPTION	Q'TY	REMARKS
1	3XP-2582T-00	DISC, brake	1	
2	90109-065F3	BOLT	6	
3	3XP-2580T-00	CALIPER ASSY (LEFT)	1	
4	3JD-W0057-00	.PISTON ASSY, caliper	1	
5	3JD-W0047-00	..CALIPER SEAL KIT	1	
6	3SP-25919-00	.SUPPORT, pad	1	
7	1UY-W0048-50	.BREED SCREW KIT	1	
8	3XP-W0045-00	.BRAKE PAD KIT	1	
9	3GD-25933-00	.PIN, pad	2	
10	90105-08659	BOLT, washer based	2	
11	3XP-25875-00	HOLDER, brake hose 1	1	



3XP1010-1270

D9

FIG. 27 REAR WHEEL

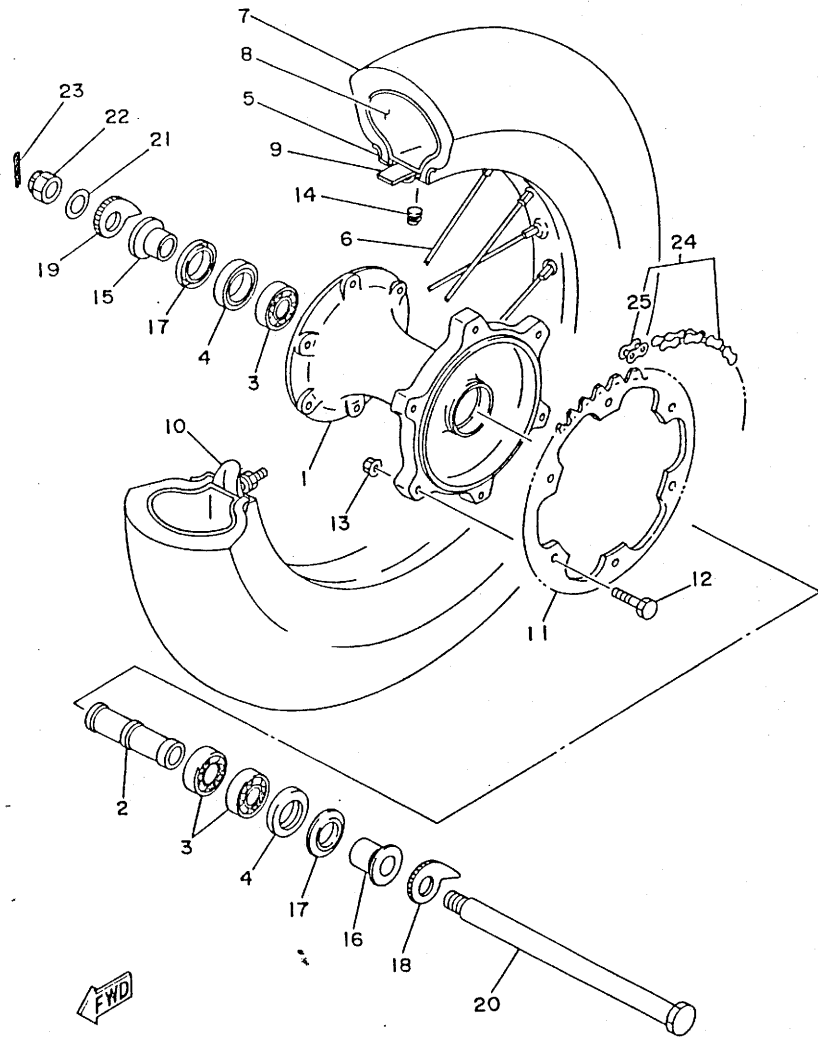

REF. NO.	PART NO.	DESCRIPTION	Q'TY	REMARKS
1	3XP-25311-00-35	HUB, rear	1	SILVER
2	90560-20278	SPACER	1	
3	93306-00438	BEARING	3	
4	93106-28023	OIL SEAL	2	
5	94418-18452	RIM (1.85-18)	1	
6	2VN-25304-00	SPOKE SET, rear	1	
7	94110-180Y2	TIRE (100/100-18 59M K695)	1	DUNLOP
8	94211-18176	TUBE (100-120/80-100-18)	1	DUNLOP
9	94309-18146	BAND, rim	1	DUNLOP
10	2X3-25394-00	SPACER, bead	1	
11	2YY-25452-00	SPROCKET, driven (52T)	1	
12	90109-08618	BOLT	6	
13	90185-08146	NUT, self-locking	6	
14	90480-10068	GROMMET	1	
15	90387-202U8	COLLAR	1	
16	90387-206X8	COLLAR	1	
17	3GB-25367-00	COVER, hub dust	2	
18	3BN-25388-00	PULLER, chain 1	1	
19	3BN-25389-00	PULLER, chain 2	1	
20	3XP-25381-00	AXLE, wheel	1	
21	90201-204H9	WASHER, plate	1	
22	95301-18900	NUT	1	
23	91401-30030	PIN, cotter	1	
24	94581-47116	CHAIN	1	
25	94681-47011	.JOINT, chain	1	

48F1100-2270

D10

FIG. 28 REAR BRAKE CALIPER

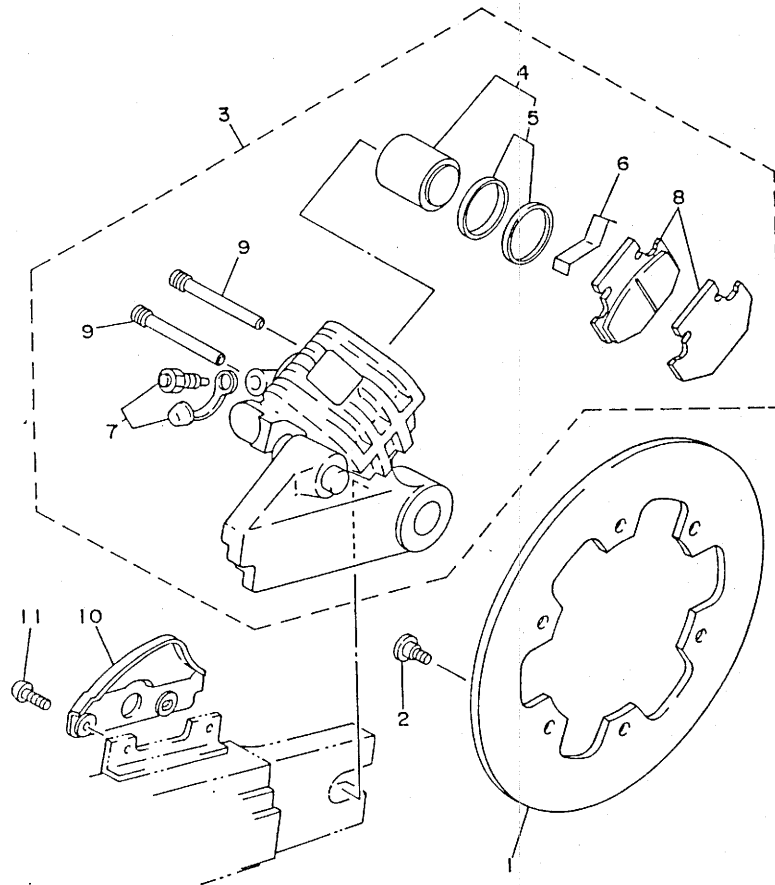

REF. NO.	PART NO.	DESCRIPTION	Q'TY	REMARKS
1	3XP-2582W-00	DISC, rear brake 2	1	
2	90109-065F3	BOLT	6	
3	3XP-2580W-00	CALIPER ASSY, rear 2	1	
4	3SP-W0057-50	.PISTON ASSY, caliper	1	
5	3JD-W0047-50	..CALIPER SEAL KIT	1	
6	3SP-25919-51	.SUPPORT, pad	1	
7	1UY-W0048-50	.BREED SCREW KIT	1	
8	3XP-W0046-00	.BRAKE PAD KIT, 2	1	
9	3SP-25924-51	.PIN, pad	2	
10	3JD-27491-00	PROTECTOR	1	
11	92011-06012	BOLT, button head	2	



3XP1010-1290

D11

FIG. 29 STEERING HANDLE. CABLE

REF. NO.	PART NO.	DESCRIPTION	Q'TY	REMARKS
1	3XJ-26111-00	HANDLEBAR	1	
2	322-26243-00	TUBE, throttle guide	1	
3	1LX-26242-01	GRIP (RIGHT)	1	
4	1M1-26249-01	RING, leaf	1	
5	1LX-26241-01	GRIP (LEFT)	1	
6	4BF-26311-00	CABLE, throttle 1	1	
7	3XP-26335-00	CABLE, clutch	1	
8	90123-08046	BOLT	1	
9	90179-08148	NUT	1	
10	3BN-26141-20	GUARD, brush 1	1	PURPLISH WHITE SOLID 1
11	3BN-26142-20	GUARD, brush 2	1	PURPLISH WHITE SOLID 1
12	1E6-26342-00	BOOT, cable	1	
13	98501-06035	SCREW, pan head	1	
14	92901-06600	WASHER, plate	1	
15	92901-06600	WASHER, plate	1	
16	95601-06100	NUT, u	1	
17	90387-06500	COLLAR	1	
18	5X2-26281-00	CAP, grip upper	1	
19	322-26282-00	CAP, grip lower	1	
20	5X2-2628H-01	CAP, wire	1	
21	98706-04012	SCREW, flat head	2	
22	98506-05016	SCREW, pan head	2	
23	90387-22660	COLLAR	1	

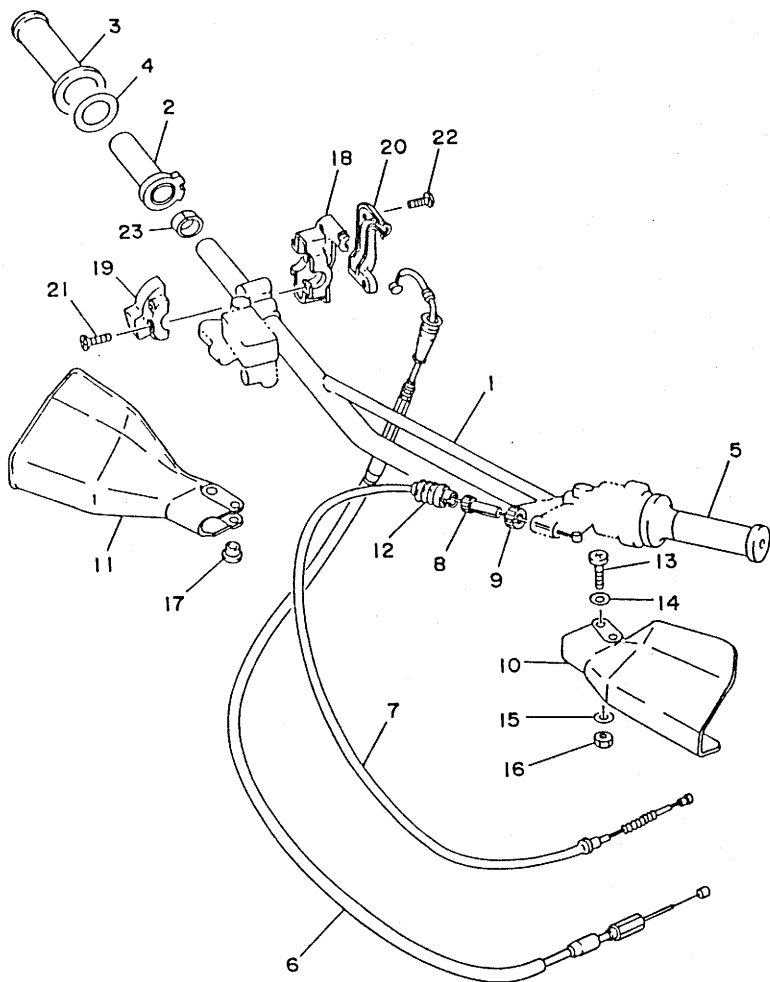

4BF1100-2290

D12

FIG. 30 FRONT MASTER CYLINDER

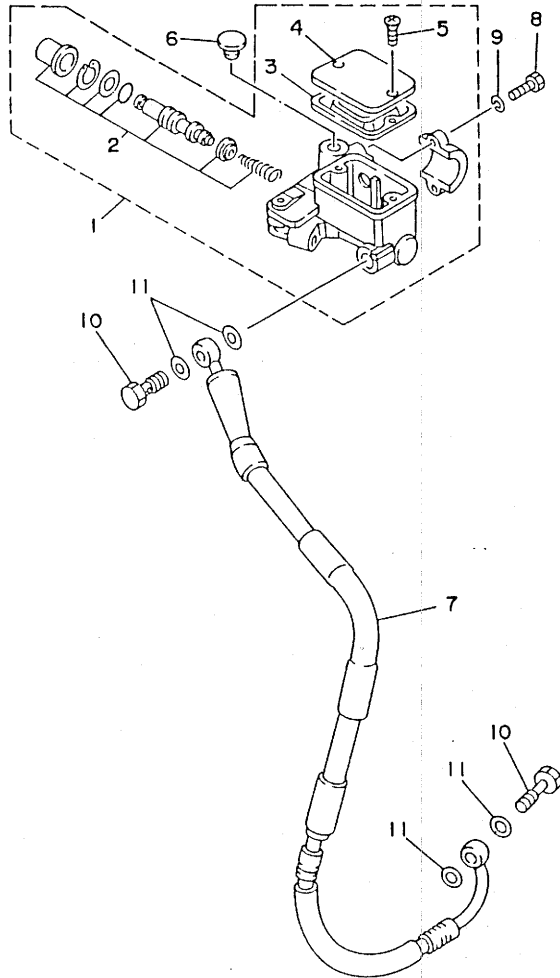

REF. NO.	PART NO.	DESCRIPTION	Q'TY	REMARKS
1	3XP-2583T-00	MASTER CYLINDER ASSY	1	
2	3XP-W0041-00	.CYLINDER KIT, master	1	
3	55U-25854-00	.DIAPHRAGM, reservoir	1	
4	2KF-25852-01	.CAP, reservoir	1	
5	98706-04012	.SCREW, flat head	2	
6	90338-09012	PLUG	1	
7	4BF-25872-00	HOSE, brake 1	1	
8	97016-06025	BOLT	2	
9	92906-06100	WASHER, spring	2	
10	90401-10034	BOLT, union	2	
11	90201-10118	WASHER, plate	4	



4BF1100-2300

D13

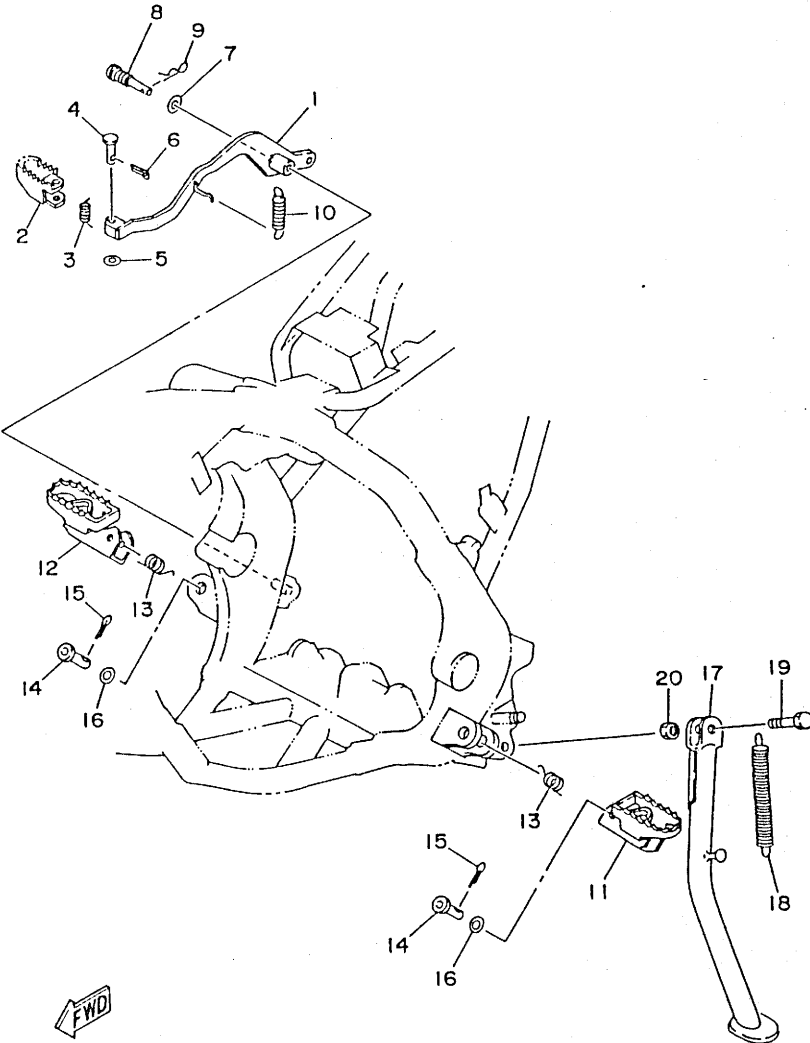

FIG. 31 STAND. FOOTREST

REF. NO.	PART NO.	DESCRIPTION	Q'TY	REMARKS
1	3XP-27211-00	PEDAL, brake	1	
2	3XP-27242-00	PEDAL, brake	1	
3	90508-14352	SPRING, torsion	1	
4	91701-06022	PIN, clevis	1	
5	92901-06600	WASHER, plate	1	
6	91401-20015	PIN, cotter	1	
7	90201-086P8	WASHER, plate	1	
8	90149-08231	SCREW	1	
9	90468-10050	CLIP	1	
10	90506-14453	SPRING, tension	1	
11	3SP-27411-00	FOOTREST 1	1	
12	3SP-27421-00	FOOTREST 2	1	
13	90508-28777	SPRING, torsion	2	
14	90240-10117	PIN, clevis	2	
15	91401-25015	PIN, cotter	2	
16	90201-10119	WASHER, plate	2	
17	3XP-27311-00-35	STAND, side	1	SILVER
18	90506-35474	SPRING, tension	1	
19	90109-10474	BOLT	1	
20	90185-10037	NUT, self-locking	1	

4BF1100-2310

D14

FIG. 32 REAR MASTER CYLINDER

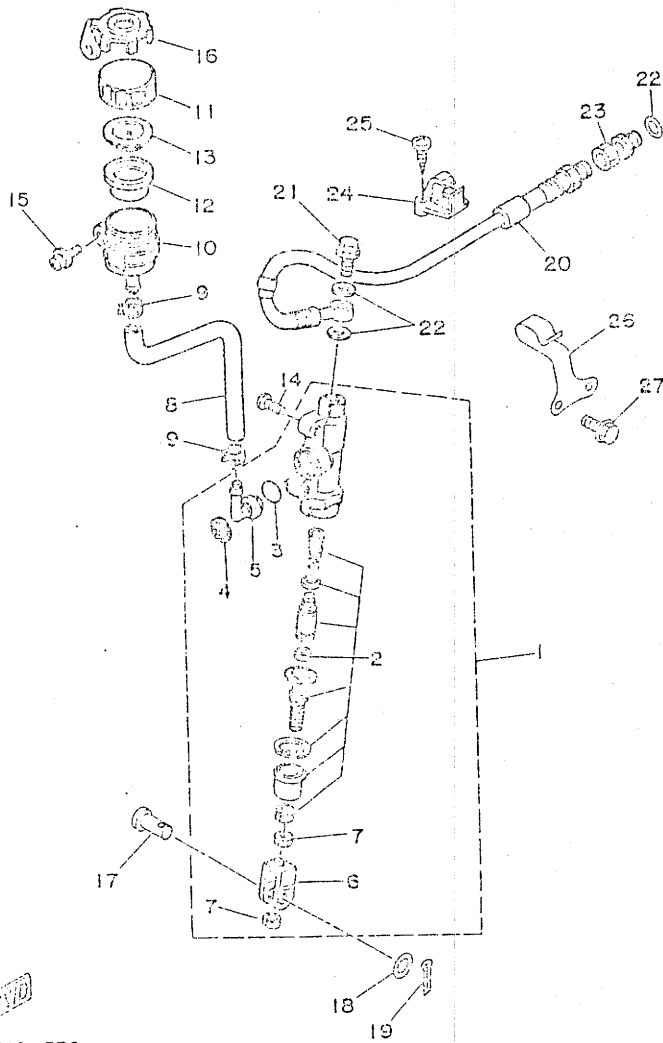

REF. NO.	PART NO.	DESCRIPTION	Q'TY	REMARKS
1	3XP-2563V-00	RR. MASTER CYLINDER ASSY.	1	
2	3EN-110042-60	.CYLINDER KIT, master	1	
3	93210-15620	.O-RING	1	
4	2VN-25266-00	.CIRCLIP	1	
5	2VN-2532A-50	.JOINT	1	
6	2YK-27222-00	.JOINT	1	
7	95303-02600	.NUT	2	
8	3XP-25895-00	HOSE, reservoir	1	
9	90467-11044	CLIP	2	
10	2VN-25894-00	TANK, reservoir	1	
11	3XP-25892-50	CAP, reservoir	1	
12	2VN-25354-00	DIAPHRAGM, reservoir	1	
13	2VN-25355-00	BUSH, diaphragm	1	
14	92011-02016	BOLT, button head	2	
15	90159-06056	SCREW, with washer	1	
16	3ET-25838-00	COVER, reservoir tank	1	
17	90240-03124	PIN, clevis	1	
18	90201-02083	WASHER, plate	1	
19	91401-16015	PIN, cotter	1	
20	3XP-25873-01	HOSE, brake 2	1	
21	90401-10034	BOLT, union	1	
22	90201-10113	WASHER, plate	3	
23	3LC-25085-00	JOINT	1	
24	3EN-25876-00	HOLDER, brake hose 2	1	
25	97780-50516	SCREW, tapping	2	
26	90462-12195	CLAMP	1	
27	95023-06003	BOLT	2	

3XP1010-1330

D15

FIG. 33 GENERATOR

REF. NO.	PART NO.	DESCRIPTION	Q'TY	REMARKS
1	4BF-85550-00	ROTOR ASSY	1	
2	4BF-85560-00	BASE ASSY	1	
3	37A-85520-M1	.COIL, charge	1	
4	4BF-81313-00	.COIL, lighting 1	1	
5	4BF-81314-00	.COIL, lighting 2	1	
6	4BF-85595-00	.COIL, pulser	1	
7	98503-04014	.SCREW, pan head	2	
8	98511-04025	.SCREW, pan head	4	
9	98580-04008	.SCREW, pan head	2	
10	97601-04106	.SCREW, pan head with washer	3	
11	98511-04006	.SCREW, pan head	1	
12	90179-12421	NUT	1	
13	90201-123L6	WASHER, plate	1	

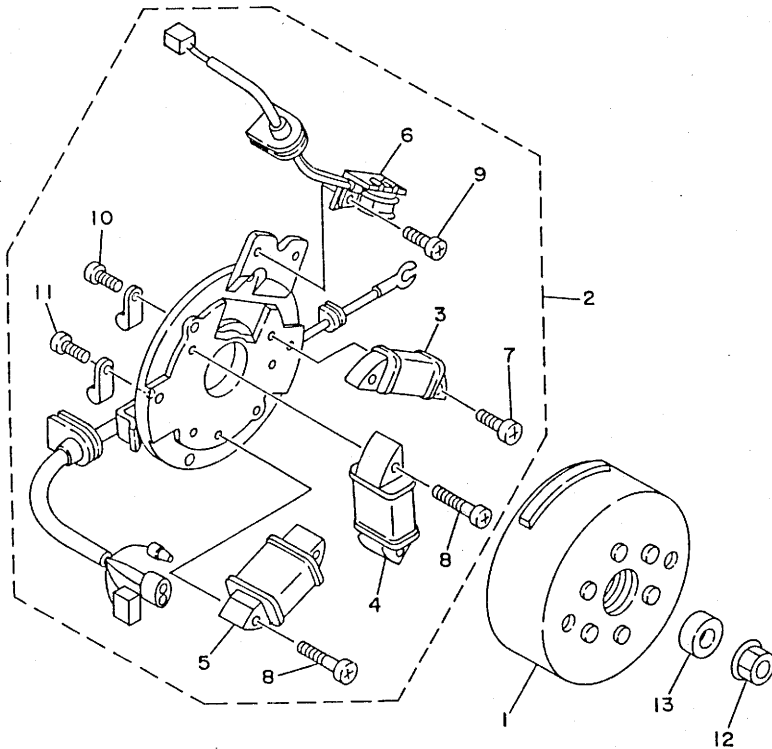

FWD

4BF1100-2330

E2

FIG. 34 METER

REF. NO.	PART NO.	DESCRIPTION	Q'TY	REMARKS
1	4BF-83500-00	SPEEDOMETER ASSY	1	UR FOR USA
	4BF-83500-10	SPEEDOMETER ASSY	1	UR FOR EUROPE/OCEANIA
2	3R8-83578-00	.KNOB, trip meter	1	
3	90157-02031	.SCREW, pan head	1	
4	95811-06016	BOLT, flange	2	
5	3XP-83550-00	SPEEDOMETER CABLE ASSY	1	

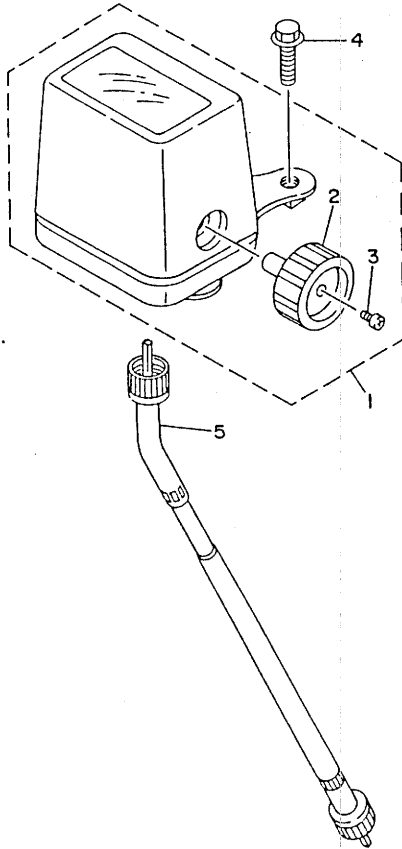

4BF1100-2340

E3

FIG. 35 HEADLIGHT

REF. NO.	PART NO.	DESCRIPTION	Q'TY	REMARKS
1	3XP-84320-00	LENS ASSY	1	
2	3FW-84314-00	BULB, headlight	1	
3	3FW-84340-00	SOCKET CORD ASSY 1	1	
4	3XP-84311-00	BODY, headlight	1	
5	55U-84332-00	SPRING, screw	1	
6	50W-84334-00	NUT, adjusting	1	
7	849-84724-00	SCREW, lens fitting	1	
8	55U-84337-00	BOLT, special	2	
9	55U-84328-00	SPACER	2	
10	3XP-84196-00	COVER, socket	1	
11	3XP-84118-00	STAY, headlight 1	2	
12	3XP-84145-00	COLLAR, body fitting	2	
13	97016-06016	BOLT	2	
14	92901-04600	WASHER, plate	1	
15	95816-06012	BOLT, flange	2	
16	3XP-84141-11	EMBLEM, headlight	1	

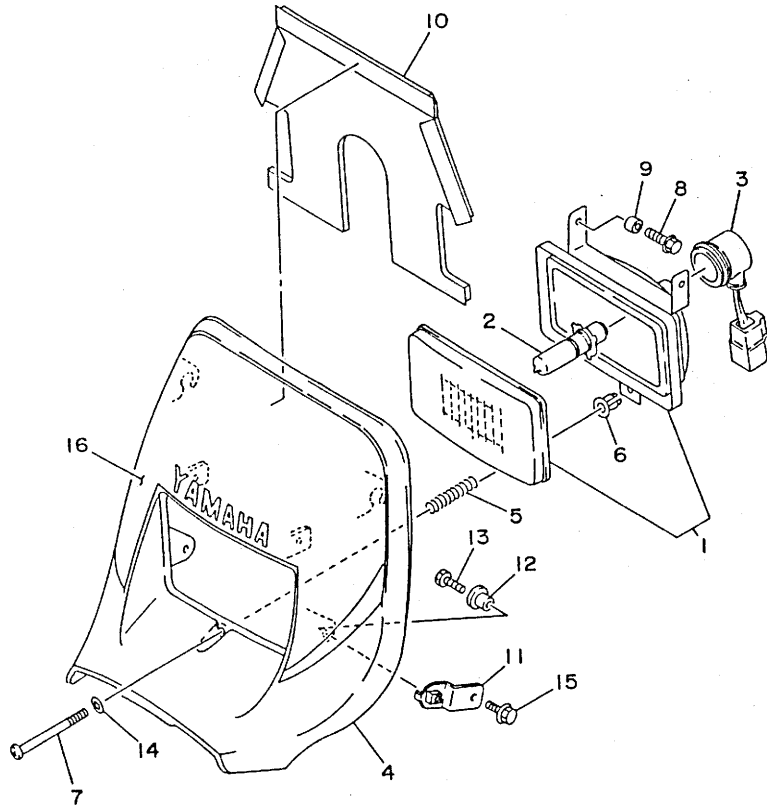

3XP1010-1370

E4

FIG. 36 TAILLIGHT

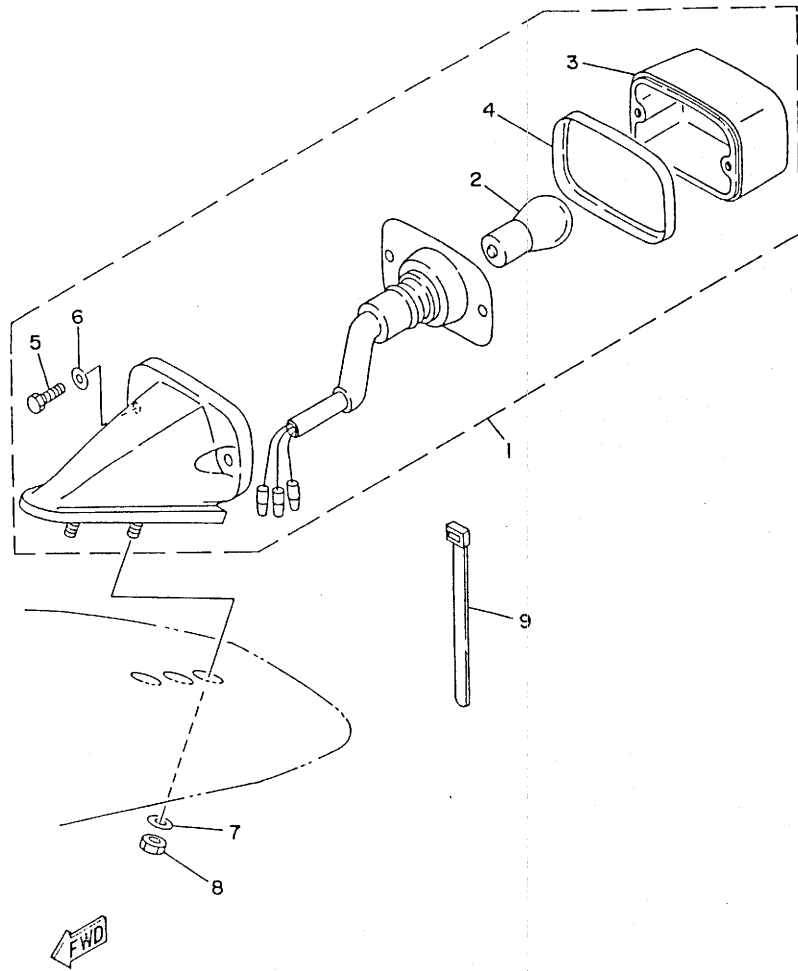

REF. NO.	PART NO.	DESCRIPTION	Q'TY	REMARKS
1	4BF-84700-00	TAILLIGHT ASSY	1	
2	27V-84714-00	.BULB (12V-18/5W)	1	
3	434-84521-69	.LENS, taillight	1	
4	434-84515-61	.RIM, taillight	1	
5	434-84552-62	.BOLT, fitting	2	
6	434-84522-62	.WASHER	2	
7	92901-05600	WASHER, plate	2	
8	95601-05100	NUT, u	2	
9	1UA-82591-00	BAND	1	

4BF1100-2360

E5

FIG. 37 HANDLE SWITCH. LEVER

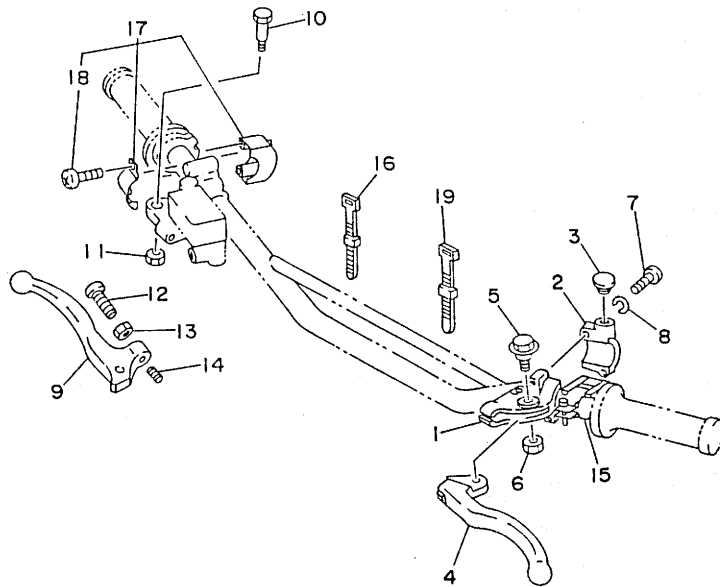

REF. NO.	PART NO.	DESCRIPTION	Q'TY	REMARKS
1	1LN-82911-00	HOLDER, lever 1	1	
2	33G-82913-00	HOLDER, lever lower 1	1	
3	90338-09012	PLUG	1	
4	23X-83912-00	LEVER 1	1	
5	90109-06799	BOLT	1	
6	95616-06100	NUT, u	1	
7	98506-05020	SCREW, pan head	2	
8	92906-05100	WASHER, spring	2	
9	3JD-83922-00	LEVER 2	1	
10	90109-062A8	BOLT	1	
11	95616-06100	NUT, u	1	
12	90149-06131	SCREW	1	
13	90170-06355	NUT	1	
14	90501-10312	SPRING, compression	1	
15	23X-83976-00	SWITCH, handle 1	1	
16	437-83936-01	BAND, switch cord	2	
17	4BF-83976-00	SWITCH, handle 1	1	
18	98506-04012	SCREW, pan head	2	
19	437-83936-01	BAND, switch cord	2	



4BF1100-2370

E6

FIG. 38 ELECTRICAL 1

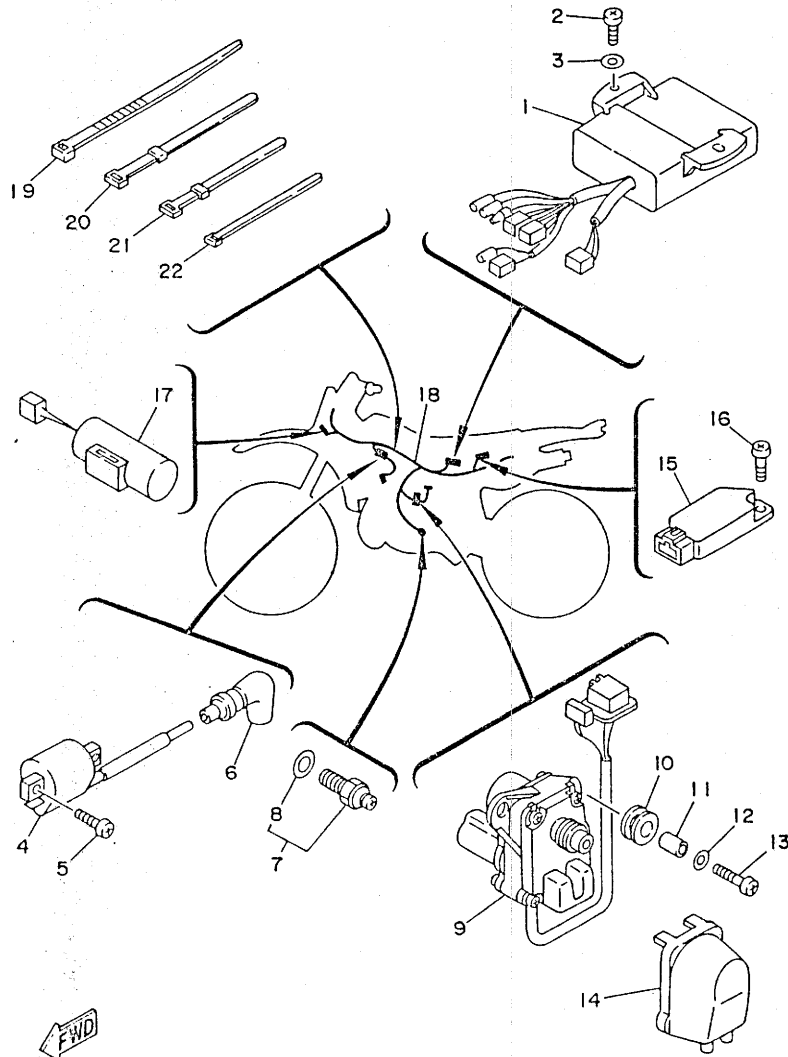

REF. NO.	PART NO.	DESCRIPTION	Q'TY	REMARKS
1	4BF-85540-00	C.D.I. UNIT ASSY	1	
2	98502-06016	SCREW, pan head	2	
3	92990-06600	WASHER, plate	2	
4	3XP-82310-00	IGNITION COIL ASSY	1	
5	98502-06016	SCREW, pan head	2	
6	2TV-82370-00	PLUG CAP ASSY	1	WITH NOISE SUPPRESSOR
7	2H7-82540-00	NEUTRAL SWITCH ASSY	1	
8	341-82543-00	.GASKET	1	
9	3XP-85820-00	SERVO MOTOR ASSY	1	
10	90480-14023	GROMMET	2	
11	90387-06299	COLLAR	2	
12	90201-06067	WASHER, plate	2	
13	98501-06025	SCREW, pan head	2	
14	34X-85825-00	COVER, wire	1	
15	1JK-81960-A1	RECTIFIER & REGULATOR ASSY	1	
16	98502-06012	SCREW, pan head	2	
17	1NL-81965-00	CONDENSER, smoothing	1	
18	4BF-82590-00	WIRE HARNESS ASSY	1	
19	12R-82591-00	BAND	2	
20	3TB-83936-00	BAND, switch cord	2	
21	437-83936-11	BAND, switch cord	1	
22	341-26397-01	BAND	1	

FWD

4BF1100-2380

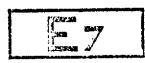

NUMERICAL INDEX

PART NO.	GRID NO.	PART NO.	GRID NO.	PART NO.	GRID NO.	PART NO.	GRID NO.	PART NO.	GRID NO.	PART NO.	GRID NO.
3XP-W0041-00	D-13	1LU-1248A-01	B- 8	3XP-14714-00	B-13	3BN-17161-02	C- 5	4U5-2176E-00	C-11	3XP-23136-00	D- 4
3BN-W0042-50	D-15	3XP-12481-00	B- 7	3XP-14718-00	B-13	4BF-17211-00	C- 5		C-11	3SP-2314E-L0	D- 5
3XP-W0045-00	D- 9	3XP-12482-00	B- 7	2GU-14752-00	B-13	3BN-17221-00	C- 5	4BF-21781-00	C-12	3SP-2314F-L0	D- 5
3XP-W0046-00	D-11	3XP-12483-00	B- 7	4BF-14753-00	B-13	3BN-17231-01	C- 5		C-12	3SP-2314G-L0	D- 5
3JD-W0047-00	D- 9	3XP-12484-00	B- 7	565-14771-00	B-13	3XP-17241-00	C- 5	3XP-21782-10	C-12	3SP-2314H-L0	D- 5
3JD-W0047-50	D-11	3XP-12485-00	B- 8	3XP-1490J-10	B-11	3BN-17251-02	C- 5		C-12	3XP-2314J-L0	D- 5
1UY-W0048-50	D- 9	3MT-13116-00	B-15	3XP-14931-00	B-11	3XP-17261-00	C- 5	4BF-2179X-00	C- 9	4BF-23141-00	D- 4
	D-11	3XP-13565-00	B- 9	3XP-14987-00	B-11	4BF-17411-00	C- 5	22W-21791-00	C-11		D- 5
	D- 9	3XP-13591-00	B-10	1KT-14994-00	B-11	3BN-17421-00	C- 5		C-11	3XP-23142-00	D- 4
3SP-W0057-50	D-11	1LX-13610-01	B- 9	3XP-15111-00	B-14	4BF-17471-00	C- 6		C-12		D- 5
3XP-11111-00	B- 2	55Y-13613-00	B- 9	3XP-15121-00	B-14	10W-18101-03	C- 8		C-11	3SP-23143-L0	D- 4
3XP-11181-00	B- 2	55Y-13616-00	B- 9	37F-15128-00	B-14	3XP-18110-00	C- 8	1AA-21815-00	C-13		D- 5
3XP-1131A-00	B- 2	3XP-13621-00	B- 9	4BF-15189-00	B-15	1W6-18113-00	C- 8	26H-21828-00	C-13	3GH-23144-50	D- 4
3RR-1131E-00	B- 2	3XP-1410A-00	B-11	3BN-15199-00	B-14	3BN-18140-00	C- 7	3XP-21871-00	C-13		D- 4
2RH-1131M-10	B- 2	4BF-14101-00	B-11	328-15316-00	B-14	55K-18511-01	C- 7	4BF-22110-00-T9	C-14	3LC-23145-00	D- 4
3RR-1131N-00	B- 2	3XP-14103-00	B-11	3XP-15317-00	B-14	2RH-18512-00	C- 7	3JD-22128-00	C-14		D- 4
2RH-1131R-10	B- 2	3XP-14104-00	B-11	4BF-15357-00	B-15	55K-18513-00	C- 7	1LX-22141-00	C-14	36Y-23146-10	D- 4
31K-1131U-00	B- 2	3XP-14112-40	B-11	3Y1-15361-00	B-15	55K-18531-00	C- 7	3JD-22147-00	C-14		D- 4
3XP-11311-00	B- 2	8A7-14139-00	B-11	1RG-15363-00	B-15	3BN-18535-00	C- 7	3XP-22151-00	C-14	26H-23156-00	D- 4
29L-1132E-00	B- 2	3XP-14141-28	B-11	3YJ-15371-00	B-14	3XP-18540-00	C- 7	3JD-22156-00	C-14		D- 4
3XP-1133E-00	B- 3	193-14142-35	B-11	3ET-15379-00	B-15	4BF-21110-00-UJ	C- 9	3XP-2217A-00	C-14	2HH-23158-L0	D- 4
3BN-1133F-00	B- 3	137-14143-42-A1	B-11	3BN-15411-10	B-15	1JK-21268-00	C- 9	3XP-2217F-00	C-15		D- 5
3XP-11351-00	B- 2	313-14146-00	B-11	4BF-15416-00	B-15	4BF-2138K-01	C-11	30X-22178-00	C- 9	4BF-2316A-00	D- 4
3XP-11400-00	B- 4	3JD-14147-00	B-11	3XP-15421-00	B-15	4BF-2138L-00	C-11	3XJ-2218A-00	C-15		D- 5
3XP-11412-00	B- 4	137-14153-00	B-11	161-15426-00	B-15	3XP-21415-00	C- 9	10V-22184-00	C- 9	3XJ-23167-L0	D- 5
3XP-11422-00	B- 4	127-14161-00	B-11	3BN-15451-10	B-15	3XP-21425-00	C- 9	30X-2219X-00	C-14	3XP-23170-00	D- 4
2TV-11454-00	B- 4	239-14172-08	B-12	2RH-15492-00	B-14	2K7-2148A-00	C- 9	3XP-22199-00	C-14		D- 4
55K-11530-00	B- 4	3XP-14185-00	B-11	3XP-15620-00	C- 2	3XP-21511-00	C-10	4BF-22201-00	D- 2	3JD-23171-L0	D- 4
10V-11536-01	B- 4	353-14186-00	B-11	3XP-15621-00	C- 2	4BF-21611-00	C-10	4BF-22201-10	D- 2		D- 4
3XP-11610-00	B- 4	3XP-14190-30	B-11	10V-15641-00	C- 2	3XP-21639-00	C-10	4BF-22210-00-PO	D- 2	4BF-23174-00	D- 3
3XP-11631-00-A0	B- 4	12R-14191-00	B-11	10V-15651-00	C- 2	39X-21642-00	C-10	4BF-22210-10-PO	D- 2	4V4-23194-L0	D- 5
3XP-11631-00-B0	B- 4	3KD-14197-00	B-11	10V-15660-00	C- 2	3XP-2165A-11	C-10	23X-22211-00	D- 2	3XP-23318-00	D- 3
3XP-11631-00-C0	B- 4	310-14197-00	B-11	10V-15666-00	C- 2	3XP-21711-00	C-11	4BF-22212-00-PO	D- 2	3XP-23318-10	D- 5
3XP-11631-00-D0	B- 4	3XP-14229-00	B-11	3RR-16111-00	C- 3	3XJ-21717-00	D- 6	3XP-22214-00	D- 2	3XP-23340-00	D- 5
4H7-11633-00	B- 4	3XP-14261-00	B- 9	3XP-16150-00	C- 3	3XJ-2172A-00	C-11	3XP-22224-00	D- 2	3SP-23346-L0	D- 5
2TV-11651-00	B- 4	3XP-14411-00	B- 9	2TV-16154-00	C- 3	3XJ-2172F-00	C-12	3SP-22241-00	D- 2	3XP-23346-00	D- 5
37F-11681-00	B- 4	3XP-14412-00	B- 9	21V-16321-00	C- 3	3MA-2172N-00	C-13	3XP-22475-00	C-15	3SP-23356-L0	D- 5
4BF-1240A-00	B- 7	3XP-14421-00	B- 9	1V1-16324-00	C- 3	3XP-21721-00	C-11	4BF-23102-00	D- 4	3XP-23389-00	D- 3
3BN-12414-10	B- 7	3AJ-1443E-00	B- 9	1HX-16331-00	C- 3	3XP-2173E-11	C-12	4BF-23103-00	D- 4	3XP-23389-10	D- 5
3BN-12422-11	B- 6	43G-14436-00	B- 9	4H7-16340-00	C- 3	3XP-2173L-11	C-12	3XP-23110-00	D- 4	5Y3-23393-00	D- 5
3BN-12428-10	B- 6	3XP-14437-00	B- 9	3XP-16351-00	C- 3	4BF-21731-00	C-11	3XP-23111-00	D- 4	3XP-23416-00	D- 3
36F-12450-00	B- 6	4BF-14451-00	B- 9	3LD-1637A-00	C- 3	3XP-2174A-00	C-12		D- 5	26H-23418-01	D- 3
2TV-12459-00	B- 6	3XP-14453-00	B- 9	2TV-16371-00	C- 3	3XP-2174F-00	C-12	55Y-2312G-M0	D- 4	4BF-23435-01-35	D- 3
3XP-12460-00	B- 7	3XP-14458-00	B- 9	3JD-16382-00	C- 4	3XP-2174T-00	C-12		D- 5	1E6-23441-10-35	D- 3
3XP-12462-00	B- 7	3XP-14459-00	B- 9	3BN-16383-00	C- 3	4BF-21741-00	C-11	3XP-23120-00	D- 4	3XP-23462-00	D- 3
3BN-12469-00	B- 7	3XP-14610-00	B-13	3BN-17121-00	C- 5	3XP-21746-00	C-12	3JD-23125-L0	D- 4	3XP-23778-00	D- 4
3XP-12469-00	B- 8	2GU-14613-00	B-13	3BN-17131-01	C- 5	3XP-21747-00	C-12		D- 4		D- 5
3XP-12476-00	B- 8	3PA-14613-10	B-13	3BN-17151-01	C- 5	56J-21747-00	C- 9	3XP-23136-00	D- 4	4BF-24110-00	D- 6

NUMERICAL INDEX

PART NO.	GRID NO.	PART NO.	GRID NO.	PART NO.	GRID NO.	PART NO.	GRID NO.	PART NO.	GRID NO.	PART NO.	GRID NO.
5X6-2412F-00	D- 6	3SP-25919-00	D- 9	3JD-83922-00	E- 6	90109-10474	D-14	90179-25614	D- 3	90209-06096	B- 9
24X-24144-00	D- 6	3SP-25919-51	D-11	3TB-83936-00	E- 7	90116-08042	B-13	90179-25615	D- 3	90209-18135	C- 5
4BF-24173-00	D- 6	3SP-25924-51	D-11	437-83936-01	E- 6	90116-08318	B- 2	90185-08146	D-10	90209-22257	B- 4
1LX-24181-00	D- 6	3GD-25933-00	D- 9		E- 6	90116-08388	B- 2	90185-10037	D-14	90215-12271	C- 3
3XP-24311-00	D- 6	3XJ-26111-00	D-12	437-83936-11	E- 7	90116-08394	B- 2	90185-10060	C- 9	90215-12272	B- 4
3BN-24500-00	D- 6	3BN-26141-20	D-12	23X-83976-00	E- 6	90119-05001	C- 3	90185-14070	C-15	90215-20283	C- 5
4X8-24512-00	D- 6	3BN-26142-20	D-12	4BF-83976-00	E- 6	90119-06043	D- 7	90185-16127	C-14	90240-08124	D-15
1UY-24610-00	D- 6	1LX-26241-01	D-12	3XP-84118-00	E- 4	90119-06097	C-10	90201-060A3	B-13	90240-10117	D-14
509-24724-00	D- 7	1LX-26242-01	D-12	3XP-84141-11	E- 4	90119-06118	B-10	90201-06067	E- 7	90267-40075	B- 9
4BF-24731-00	D- 7	322-26243-00	D-12	3XP-84145-00	E- 4	90119-06194	C-10	90201-062A8	C-11	90280-03045	B- 4
4BF-24770-00	D- 7	1M1-26249-01	D-12	3XP-84196-00	E- 4	90119-06205	C-13		C-11	90282-05047	B- 4
550-25104-00	D- 8	5X2-2628H-01	D-12	3XP-84311-00	E- 4	90119-06206	D- 6	90201-06570	B- 7	90282-05058	B- 4
3XP-25111-00-35	D- 8	5X2-26281-00	D-12	3FW-84314-00	E- 4	90119-06207	C-10		B- 7	90338-09012	D-13
322-25118-00	D- 8	322-26282-00	D-12	3XP-84320-00	E- 4	90122-06013	B- 9	90201-08083	D-15		E- 6
55U-25181-01	D- 8	4BF-26311-00	D-12	55U-84328-00	E- 4	90123-08046	D-12	90201-08087	B-15	90338-10150	C-14
3XP-25190-00	D- 8	3XP-26335-00	D-12	55U-84332-00	E- 4	90149-06011	D- 6	90201-081H4	B-13	90338-16029	B-14
2VN-25304-00	D-10	1E6-26342-00	D-12	50W-84334-00	E- 4	90149-06131	E- 6	90201-08512	B- 6	90380-22111	C-14
3XP-25311-00-35	D-10	341-26397-01	C-13	55U-84337-00	E- 4	90149-06165	D- 6	90201-086P8	D-14	90387-062H9	C-11
3GB-25367-00	D-10		E- 7	3FW-84340-00	E- 4	90149-06200	B- 9	90201-08649	B- 2		C-11
3XP-25381-00	D-10	157-27114-00	B-13	434-84515-61	E- 5	90149-06223	C-11	90201-08753	C- 9	90387-062V8	C-10
3BN-25388-00	D-10	3XP-27211-00	D-14	434-84521-69	E- 5		C-11	90201-08759	C-15	90387-06241	B-10
3BN-25389-00	D-10	2YK-27222-00	D-15	434-84522-62	E- 5	90149-08231	D-14	90201-100E9	C- 9	90387-06299	E- 7
2X3-25394-00	D-10	3XP-27242-00	D-14	434-84552-62	E- 5	90154-05063	C-11	90201-10118	D-13	90387-06387	D- 6
5X2-25394-00	D- 8	3XP-27311-00-35	D-14	4BF-84700-00	E- 5		C-11		D-15	90387-06500	D-12
2YY-25452-00	D-10	3SP-27411-00	D-14	27V-84714-00	E- 5	90157-02031	E- 3	90201-10119	C- 3	90387-06737	B-10
3XP-2580T-00	D- 9	3SP-27421-00	D-14	849-84724-00	E- 4	90157-05079	C-11		D-14	90387-07392	B- 7
3XP-2580W-00	D-11	3JD-27491-00	D-11	37A-85520-M1	E- 2		C-12	90201-106F2	C-15	90387-07573	B- 7
2VN-2582A-50	D-15	3XP-28100-00	C- 9	4BF-85540-00	E- 7	90157-06115	B-15	90201-120E8	C- 3	90387-100Y3	D- 2
3XP-2582T-00	D- 9	1AE-2834F-00	B-10	4BF-85550-00	E- 2	90159-05183	C-11	90201-123L6	E- 2	90387-103X9	C-15
3XP-2582W-00	D-11	4BF-81313-00	E- 2	4BF-85560-00	E- 2		C-11	90201-12474	C- 3	90387-105L0	B-13
3XP-2583T-00	D-13	4BF-81314-00	E- 2	4BF-85595-00	E- 2		C-11	90201-12631	C- 2	90387-15600	D- 8
3XP-2583V-00	D-15	1JK-81960-A1	E- 7	3XP-85820-00	E- 7		C-13	90201-150H2	C- 3	90387-166X0	C-14
2KF-25852-01	D-13	1NL-81965-00	E- 7	34X-85825-00	E- 7	90159-06056	D-15	90201-154E8	C- 2	90387-166X1	C-15
3XP-25852-50	D-15	1KH-82131-00	C- 9	90101-06576	B-13	90159-06160	C-11		C- 5	90387-166X2	C-14
2VN-25854-00	D-13	3XP-82310-00	E- 7	90105-08646	C- 9		C-11	90201-160F6	C-15	90387-166X3	C-14
2VN-25855-00	D-15	2TV-82370-00	E- 7	90105-08659	D- 9	90170-06355	E- 6	90201-164H4	C-14	90387-202T9	B- 4
2VN-25866-00	D-15	2H7-82540-00	E- 7	90105-08663	C- 9	90170-12370	B- 5	90201-170M2	B-14	90387-202U8	D-10
4BF-25872-00	D-13	341-82543-00	E- 7		C- 9		C- 3	90201-180P2	C- 3	90387-205W8	C- 5
3XP-25873-01	D-15	4BF-82590-00	E- 7	90105-10614	D- 2	90176-08040	B- 2	90201-200J7	C- 2	90387-206X8	D-10
3XP-25875-00	D- 9	1UA-82591-00	E- 5	90105-10645	C- 9	90176-22050	D- 3	90201-20266	C- 5	90387-22660	D-12
3BN-25876-00	D-15	12R-82591-00	E- 7	90109-062A8	E- 6	90179-08148	D-12	90201-204M9	D-10	90401-10034	D-13
3LC-25885-00	D-15	1LN-82911-00	E- 6	90109-063F7	C- 7	90179-08270	B-13	90201-22555	C- 5		D-15
3ET-25888-00	D-15	33G-82913-00	E- 6	90109-06418	C- 3	90179-08491	B- 2	90201-251F6	C-14	90401-14147	C-15
3XP-2589E-00	C-13	4BF-83500-00	E- 3	90109-065F3	D- 9	90179-10616	C-15	90201-254H8	C-14	90430-06014	C- 3
2VN-25894-00	D-15	4BF-83500-10	E- 3		D-11	90179-12244	C- 2	90202-05187	B-13	90430-06166	B- 6
3XP-25895-00	D-15	3XP-83550-00	E- 3	90109-06799	E- 6		C- 3	90202-05193	D- 6		B- 7
3XP-25895-50	C-13	3R8-83578-00	E- 3	90109-085E2	B-13	90179-12421	E- 2	90202-26142	D- 3		B- 7
		23X-83912-00	E- 6	90109-086I8	D-10	90179-16613	C- 5	90208-18046	C- 3	90445-09304	D- 6

NUMERICAL INDEX

PART NO.	GRID NO.	PART NO.	GRID NO.	PART NO.	GRID NO.	PART NO.	GRID NO.	PART NO.	GRID NO.	PART NO.	GRID NO.
90445-094FO	C-13	90508-28777	D-14	93210-19123	B-15	95023-06008	D-15	98501-06012	C- 6		
90446-07349	B-14	90508-32553	C- 8	93210-30640	B- 2	95023-06012	D- 3		D- 6		
90450-15041	B- 8	90560-15290	D- 8	93306-00438	D-10	95023-06025	B- 7	98501-06025	B- 6		
90450-17036	B- 8	90560-20278	D-10	93306-20209	D- 8		B- 7		E- 7		
90450-22052	B- 7	91001-06012	D- 3	93306-20211	C- 5	95023-08012	C- 9	98501-06030	B-15		
	B- 7	91311-05010	B- 2	93306-20335	B- 4		C-12	98501-06035	D-12		
	B- 8	91311-05012	B- 2	93306-20431	C- 5	95023-08035	D- 3	98501-06040	B-15		
	B- 8	91316-05012	B- 2	93306-30210	B- 4	95023-08045	C-12	98501-06050	B-14		
90450-28014	B- 7	91401-16015	D-15	93306-30438	C- 5	95023-08050	C- 9	98501-06060	B-14		
90450-49020	B- 9	91401-20015	D-14	93306-30556	B- 4	95026-06020	B- 9	98501-06065	B- 6		
90450-99013	B- 9	91401-25015	D-14	93310-316C9	B- 4	95026-08040	D- 3		B-14		
90460-32182	B-10	91401-30030	D-10	93310-523D2	B- 4	95301-18900	D-10	98501-06070	B-14		
90460-37026	B-13	91701-06022	D-14	93311-31567	C- 5	95303-08600	D-15	98502-06012	B-14		
90460-61063	B-10	92011-06012	D-11	93315-10838	C- 4	95601-05100	E- 5		E- 7		
90462-08201	B- 2	92011-08016	D-15	93315-22046	C-14	95601-06100	D-12	98502-06016	E- 7		
90462-12195	D-15	92901-04600	B- 9		C- 4	95611-08100	C- 9		E- 7		
90467-08003	C-13		E- 4	93315-31502	C- 4	95611-08200	C- 9	98503-03008	D- 6		
	C-13	92901-05600	E- 5	93317-32231	C-14		C- 9	98503-04014	E- 2		
	D- 6	92901-06600	D-12	93332-00067	D- 3	95611-10200	D- 2	98506-04012	E- 6		
90467-10008	D- 6		D-12	93332-00068	D- 3	95616-06100	E- 6	98506-05014	B-11		
90467-11044	D-15		D-14	93340-21505	C- 3		E- 6	98506-05016	D-12		
90467-15012	B- 9	92902-04100	B-11	93399-99934	D- 2	95701-06500	C-14	98506-05020	E- 6		
90468-10050	D-14	92906-05100	E- 6	93399-99935	C-15	95701-10500	D- 5	98506-06010	C-13		
90468-15064	D- 6	92906-06100	B- 2	93410-20038	C- 5	95801-06010	B- 8	98511-04006	E- 2		
90468-26048	C- 2		C-13	93410-22039	C- 5	95801-08080	B-15	98511-04012	B-11		
90480-08216	B- 9		D-13	93430-08007	C- 2	95811-06016	E- 3	98511-04025	E- 2		
90480-09481	B-15	92906-06600	B- 2	93440-15012	C- 2	95811-06025	B- 6	98511-08010	B-14		
90480-10068	D-10		E-13	93440-30113	C-15		C-14	98516-06020	B- 7		
90480-12053	D- 3	92990-03100	B- 9		D- 2	95811-06045	C-15	98580-03008	B- 9		
90480-12067	B-10	92990-06100	D- 5	93450-17129	B- 4	95811-10016	C-15	98580-04008	E- 2		
90480-13398	C-10		D- 6	93507-32031	C- 2	95816-06012	B-13	98701-06050	C-14		
	C-11	92990-06600	E- 7	93603-22028	B- 6		E- 4	98706-04012	D-12		
	C-11	93101-12060	C- 8	93604-10011	B- 6	95816-06025	B-13		D-13		
90480-14023	E- 7	93102-15212	C- 3	93700-06004	C-15	95821-06014	C-14	98906-06010	B-13		
90480-15064	B- 7	93102-20281	D- 8	93700-06005	C-15	95826-06010	B- 7		B-13		
90480-16185	C-10	93102-20309	B- 4	9383A-13031	C- 5		B- 7	98980-06020	D- 6		
90480-18276	B- 7	93102-25331	B- 4	94108-216U5	D- 8	97011-06020	C- 8	99006-10600	C- 8		
90480-18354	D- 6	93102-26042	C- 5	94110-180Y2	D-10	97016-06016	E- 4	99009-10400	C- 3		
90480-18411	B-13	93103-10147	B- 6	94211-18176	D-10	97016-06025	D-13		C- 7		
90501-10312	E- 6	93103-32171	B- 4	94227-21123	D- 8	97026-06018	B- 2	99009-15400	C- 5		
90501-12081	C- 2	93106-22019	C-14	94309-18146	D- 8	97601-04106	E- 2	99080-07600	B- 6		
90501-20568	C- 3	93106-28023	D-10	94416-21430	D-10	97706-50520	B- 9	99244-00020	C-10		
90506-14453	D-14	93108-23010	B- 2	94418-18452	D- 8	97780-50516	D-15	99510-10114	B- 2		
90506-35474	D-14	93108-35004	C-14	94581-47116	D-10	98501-05012	D- 3	99510-12016	B-14		
90508-14352	D-14	93109-20029	C-14	94681-47011	D-10	98501-05016	B-15	99530-10014	B-15		
90508-14767	C- 3	93210-12154	B-14	94701-00188	D-10	98501-06012	B- 7				
90508-26561	C- 7	93210-12327	B- 7	95021-06014	B- 2		B- 7				
90508-26667	C- 2	93210-15620	D-15		D- 6		B-15				

